

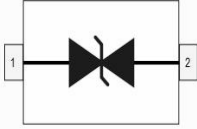

1-Line Low Capacitance Bi-directional TVS Diode

**SOD323**

**Schematic & Pin configuration**

Simplified outline	Graphic symbol
	

**General description**

GBLC05CS a 5.0V bi-directional TVS diode, utilizing leading monolithic silicon technology to provide fast response time and low ESD clamping voltage, making his device an ideal solution for protecting voltage sensitive high-speed data lines. The GBLC05CS has a low capacitance with a typical value at 0.6pF, and complies with the IEC61000-4-2(ESD) standard with  $\pm 30\text{KV}$  air and  $\pm 30\text{KV}$  contact discharge. It is assembled into a leadfree SOD-323 package. The small size, low capacitance and high ESD surge protection make GBLC05CS an idea choice to protect cell phone, wireless systems, and communication equipment.

**Features and benefits**

- Ultra Low Capacitance 0.6 pF(Typ)
- 300W peak pulse power (8/20 $\mu$ S)
- Working Voltage 5V
- Low leakage current: nA Level
- Complies with following standards:
  - IEC 61000-4-2 (ESD) immunity test
    - Air discharge:  $\pm 30\text{KV}$
    - Contact discharge:  $\pm 30\text{KV}$
  - IEC61000-4-5 (Lightning) 10A (8/20 $\mu$ S)
- RoHS compliant

**Application information**

- High- speed data lines
- Smart phones
- USB Ports
- Wireless Systems
- Ethernet 10/100/1000 Base T

**Ordering information**

Device	Packag	Packaging	Reel Size
GBLC05CS	SOD323	3000/Tape & Reel	7 inch

**Maximum Ratings** ( $T_A = 25\text{ }^\circ\text{C}$ , unless otherwise specified)

Parameter	Symbol	Value	Unit
Peak Pulse Power ( $t_p = 8/20\mu\text{s}$ )	$P_{Pk}$	160	W
Peak Pulse Current( $t_p = 8/20\mu\text{s}$ )	$I_{PP}$	10	A
ESD voltage IEC 61000-4-2 (air discharge)	$V_{ESD}$	30	KV
ESD voltage IEC 61000-4-2 (contact discharge)	$V_{ESD}$	30	KV
Storage Temperature Range	$T_{stg}$	-55 to +150	$^\circ\text{C}$
Operating Temperature Range	$T_{OP}$	-40 to +125	$^\circ\text{C}$

**Electrical Characteristics** ( $T_A = 25\text{ }^\circ\text{C}$ , unless otherwise specified)

Parameter	Symbol	Min	Typ	Max	Unit	Condition
Reverse Working Voltage	$V_{RWM}$	--	--	5.0	V	
Breakdown Voltage	$V_{BR}$	6.1	6.8	8.0	V	$I_T=1\text{mA}$
Leakage Current ILeak	$I_R$	--	--	100	nA	$V_{RWM}=5.0\text{V}$
Clamping Voltage	$V_C$	--	8.0	10.0	V	$I_{PP}=1\text{A}, t_p=8/20\mu\text{s}$
Clamping Voltage	$V_C$	--	14.0	16.0	V	$I_{PP}=10\text{A}, t_p=8/20\mu\text{s}$
Junction Capacitance	$C_J$	--	0.6	0.9	pF	$V_R=0\text{V}, f=1\text{MHz}$

**Portion Electronics Parameter**

Symbol	Parameter
$I_{PP}$	Reverse Peak Pulse Current
$V_C$	Clamping Voltage @ $I_{PP}$
$V_{RWM}$	Working Peak Reverse Voltage
$I_R$	Reverse Leakage Current @ $V_{RWM}$
$V_{BR}$	Breakdown Voltage @ $I_T$
$I_T$	$V_{BR}$ Test Current

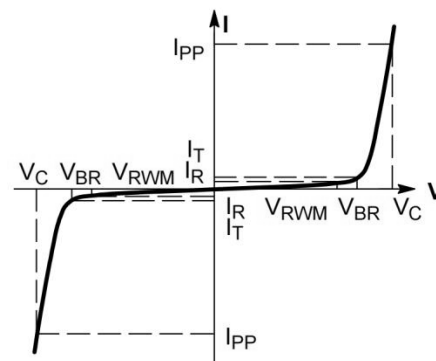

**Typical Performance Characteristics** ( $T_A=25^\circ\text{C}$  unless otherwise Specified)

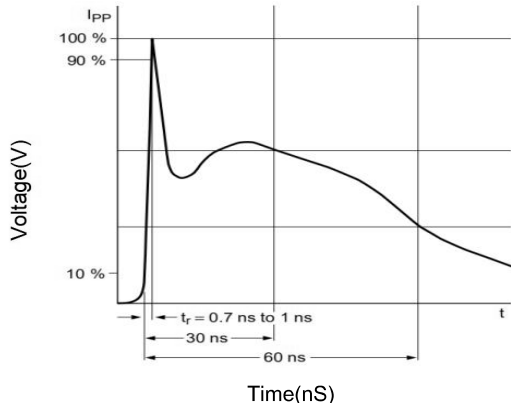

**IEC61000-4-2 Pulse Waveform**

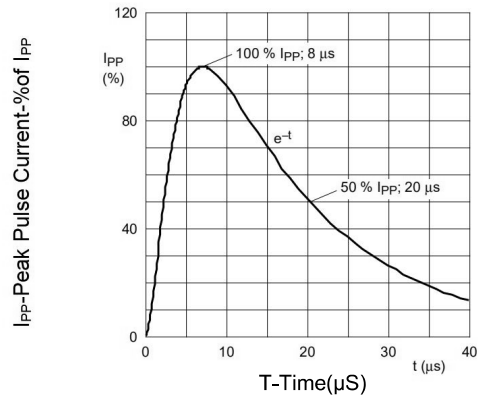

**IEC61000-4-5 8X20μS Pulse Waveform**

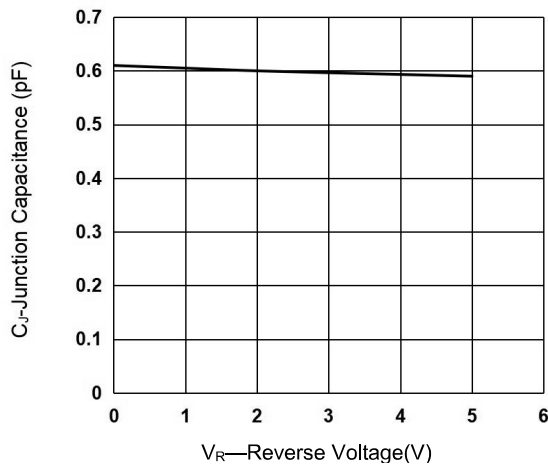

**Junction Capacitance vs. Reverse Voltage**

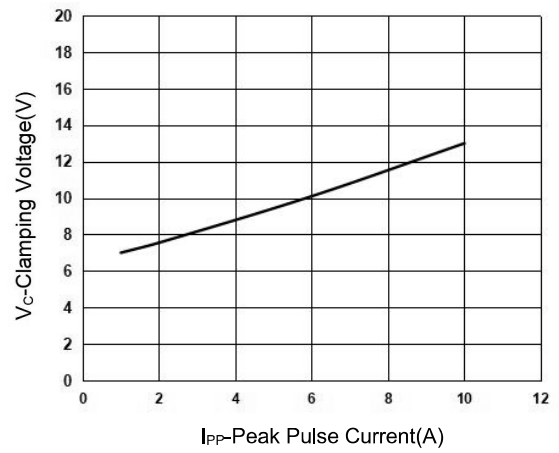

**Clamping Voltage vs. Peak Pulse Current**

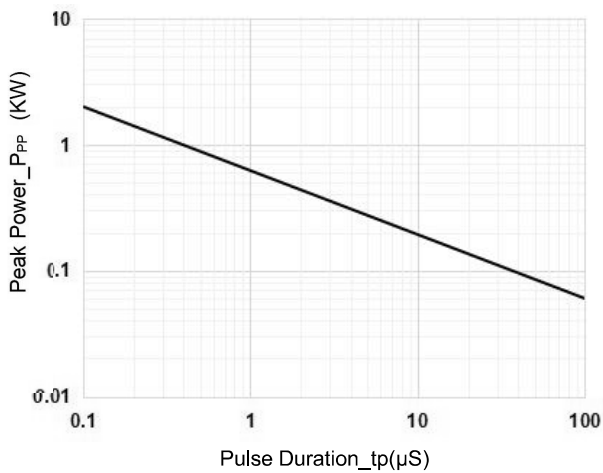

**Peak Pulse Power vs. Pulse Time**

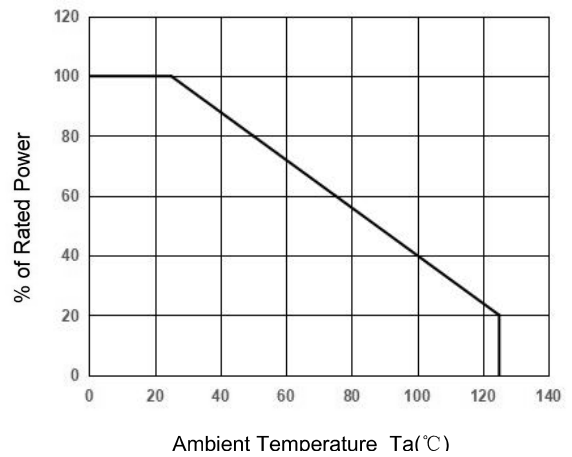

**Power Derating Curve**

**Package Outline Dimensions (mm)**

**SOD323**

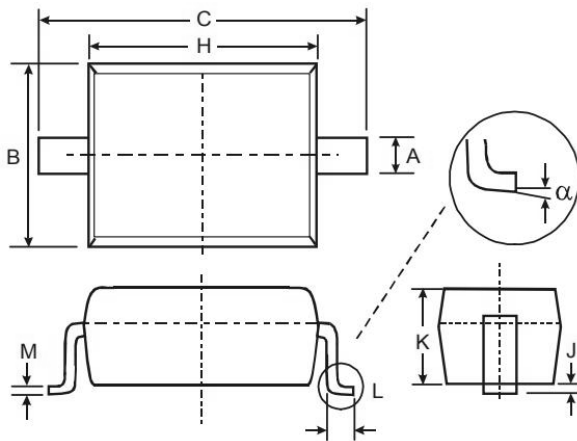

SYMBOL	DIMENSIONS	
	MIN	MAX
A	0.25	0.40
B	1.20	1.40
C	2.35	2.75
H	1.50	1.80
J	0.01	0.15
K	0.75	1.05
L	0.20	0.40
M	0.08	0.25
$\alpha$	0°	8°

**Soldering Footprint (mm)**

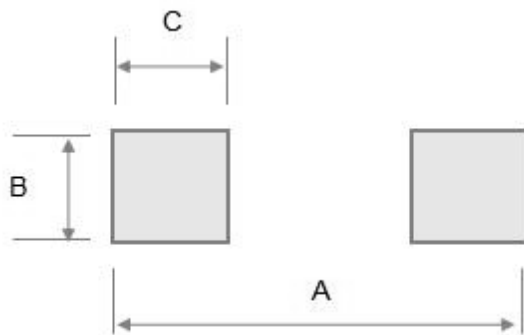

SYMBOL	DIMENSIONS
A	0.32
B	0.80
C	0.80