

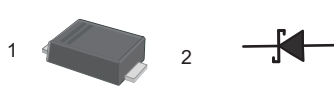
Surface Mount Schottkarrer Rectifier		Reverse Voltage - 40V Forward Current - 1.0 A							
<p><u>SOD-123FL</u></p> 		<p>Features</p> <ul style="list-style-type: none"> • Metal silicon junction, majority carrier conduction • For surface mounted applications • Low power loss, high efficiency • High forward surge current capability • For use in low voltage, high frequency inverters, free wheeling, and polarity protection applications 							
<table border="1" style="width: 100%;"> <thead> <tr> <th>PIN</th> <th>DESCRIPTION</th> </tr> </thead> <tbody> <tr> <td>1</td> <td>Cathode</td> </tr> <tr> <td>2</td> <td>Anode</td> </tr> </tbody> </table>		PIN	DESCRIPTION	1	Cathode	2	Anode	<p>Mechanical Data</p> <ul style="list-style-type: none"> • Case: SOD-123FL • Terminals: Solderable per MIL-STD-750, Method 2026 • Approx. Weight: 15mg 0.00048oz 	
PIN	DESCRIPTION								
1	Cathode								
2	Anode								
<p>Absolute Maximum Ratings and Electrical characteristics</p> <p>Ratings at 25 °C ambient temperature unless otherwise specified. Single phase, half wave, 60Hz resistive or inductive load, for capacitive load, derate by 20 %</p>									
Parameter	Symbols	MBRS140	Units						
Maximum Repetitive Peak Reverse Voltage	V_{RRM}	40	V						
Maximum RMS voltage	V_{RMS}	28	V						
Maximum DC Blocking Voltage	V_{DC}	40	V						
Maximum Average Forward Rectified Current	$I_{F(AV)}$	1.0	A						
Peak Forward Surge Current, 8.3ms Single Half Sine-wave Superimposed on Rated Load (JEDEC method)	I_{FSM}	30	A						
Max Instantaneous Forward Voltage at 1 A	V_F	0.55	V						
Maximum DC Reverse Current $T_a = 25^{\circ}C$ at Rated DC Reverse Voltage $T_a = 100^{\circ}C$	I_R	0.3 10	mA						
Typical Junction Capacitance ⁽¹⁾	C_j	110	pF						
Typical Thermal Resistance ⁽²⁾	$R_{\theta JA}$	100	°C/W						
Operating Junction Temperature Range	T_j	-55 ~ +150	°C						
Storage Temperature Range	T_{stg}	-55 ~ +150	°C						
<p>(1) Measured at 1 MHz and applied reverse voltage of 4 V D.C (2) P.C.B. mounted with 2.0" X 2.0" (5 X 5 cm) copper pad areas.</p>									

Fig.1 Forward Current Derating Curve

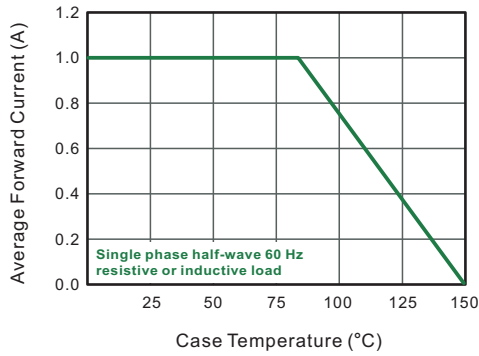


Fig.2 Typical Reverse Characteristics

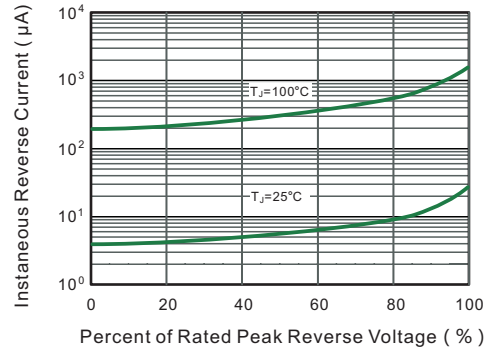


Fig.3 Typical Forward Characteristic

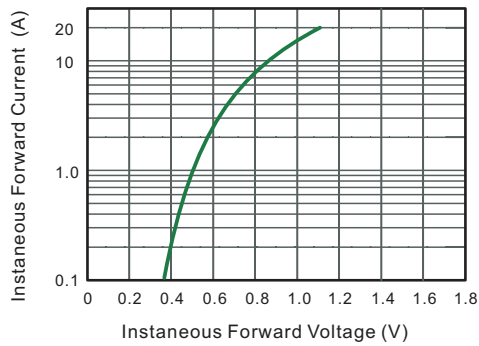


Fig.4 Typical Junction Capacitance

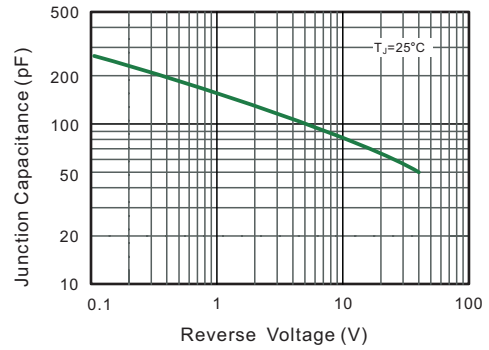


Fig.5 Maximum Non-Repetitive Peak Forward Surge Current

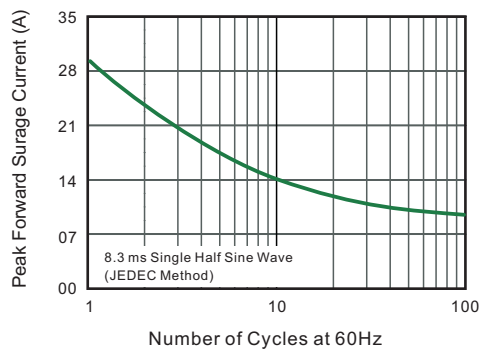
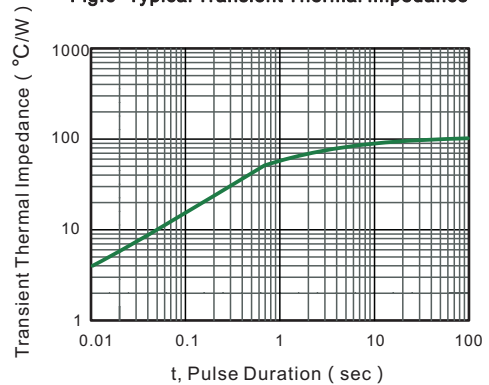


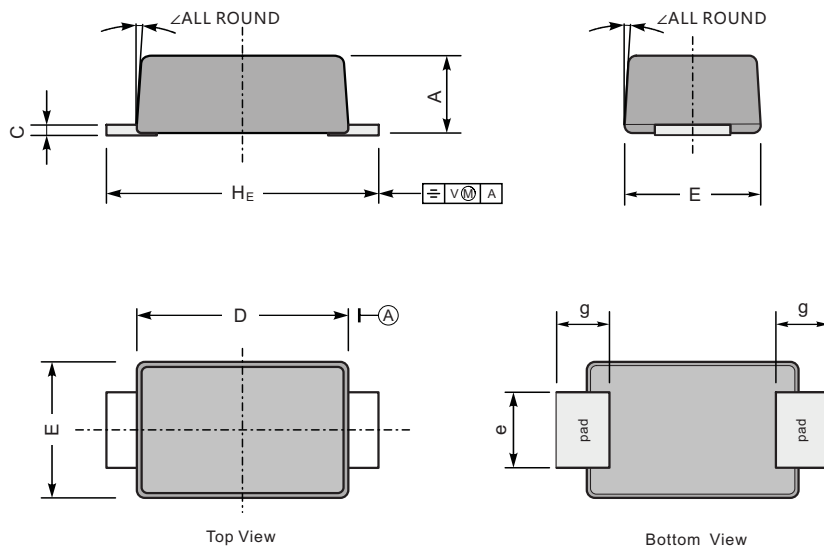
Fig.6- Typical Transient Thermal Impedance



PACKAGE OUTLINE

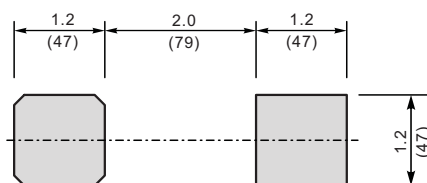
Plastic surface mounted package; 2 leads

SOD-123FL



UNIT		A	C	D	E	e	g	H _E	∠
mm	max	1.1	0.20	2.9	1.9	1.1	0.9	3.8	7°
	min	0.9	0.12	2.6	1.7	0.8	0.7	3.5	
mil	max	43	7.9	114	75	43	35	150	
	min	35	4.7	102	67	31	28	138	

The recommended mounting pad size



Unit: $\frac{\text{mm}}{\text{mil}}$

Marking

Type number	Marking code
MBRS140	X4