

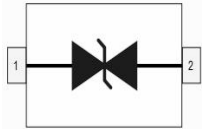

1-Line Bidirectional ESD Protection Diode

SOD323

Schematic & Pin configuration

Simplified outline	Graphic symbol
	

General description

These surge protection diodes are designed for applications requiring transient overvoltage protection capability. They are intended for use in voltage and ESD sensitive equipment such as computers, printers, business machines, communication systems, medical equipment and other applications. These devices are ideal for situations where board space is at a premium.

Features and benefits

- Bidirectional ESD protection of one line
- Femtofarad capacitance: $C_j = 10\text{pF}$ (Max)
- Response time is typically $< 1\text{ ns}$
- Low clamping voltage $V_C = 40\text{ V}$
- Ultra Low Leakage: nA Level
- IEC 61000-4-2; level 4 (ESD)
- IEC 61000-4-5 (surge); $I_{PPM} = 4\text{ A}$

Application information

- Cell Phone Handsets and Accessories
- Microprocessor based equipment
- Personal Digital Assistants (PDA's)
- Notebooks, Desktops, and Servers

Ordering information

Device	Package	Packaging	Reel Size
SD24CS	SOD323	3000/Tape & Reel	7 Inch

Maximum Ratings ($T_{OP} = 25\text{ }^{\circ}\text{C}$, unless otherwise specified)

Parameter	Symbol	Value	Unit
Peak Pulse Power ($T_p = 8/20\mu\text{s}$)	P_{PPM}	160	W
Rated Peak Pulse Current ($T_p = 8/20\mu\text{s}$)	I_{PPM}	4	A
Maximum lead temperature for soldering during 10s	T_L	260	$^{\circ}\text{C}$
Storage Temperature Range	T_{stg}	-55 to +150	$^{\circ}\text{C}$
Operating Temperature Range	T_{OP}	-40 to +125	$^{\circ}\text{C}$
Maximum junction temperature	T_j	150	$^{\circ}\text{C}$
ESD voltage IEC 61000-4-2 (air discharge)	V_{ESD}	20	kV

Electrical Characteristics ($T_{OP} = 25\text{ }^{\circ}\text{C}$, unless otherwise specified)

Parameter	Symbol	Min	Typ	Max	Unit	Condition
Reverse Working Voltage	V_{RWM}	--	--	24.0	V	
Breakdown Voltage	V_{BR}	26.0	--	30.0	V	$I_T=1\text{mA}$
Leakage Current I_{Leak}	I_R	--	--	100	nA	$V_{RWM}=24\text{V}$
Clamping Voltage	V_C	--	28	30.0	V	$I_{PP}=1.0\text{A}, T_p=8/20\mu\text{s}$
Clamping Voltage	V_C	--	39	40.0	V	$I_{PP}=4.0\text{A}, T_p=8/20\mu\text{s}$
Junction Capacitance	C_j	--	10	12	pF	$V_R=0\text{V}, f=1\text{MHz}$

Typical Characteristics

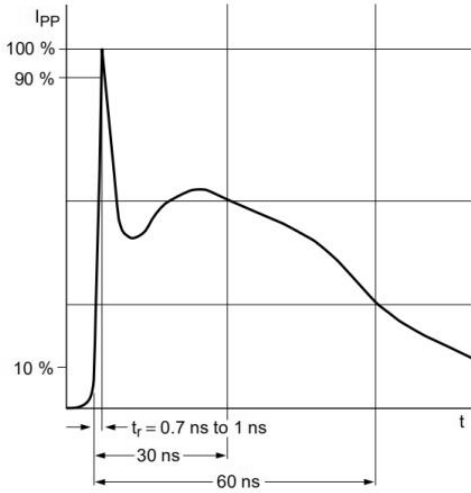

IEC61000-4-2 Waveform

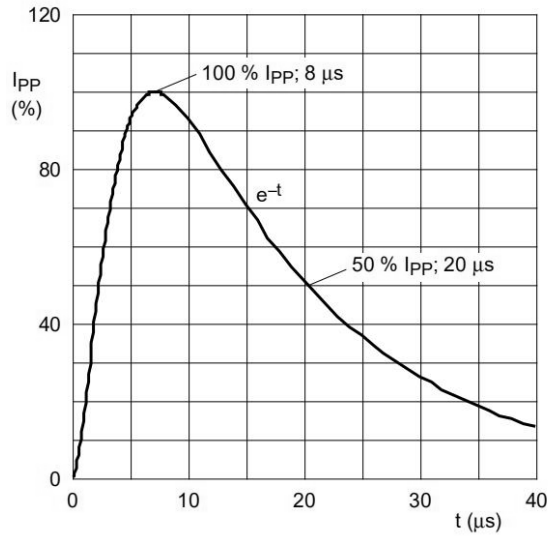

IEC 61000-4-5 Waveform(8/20µs pulse)

Package Outline Dimensions

SOD323

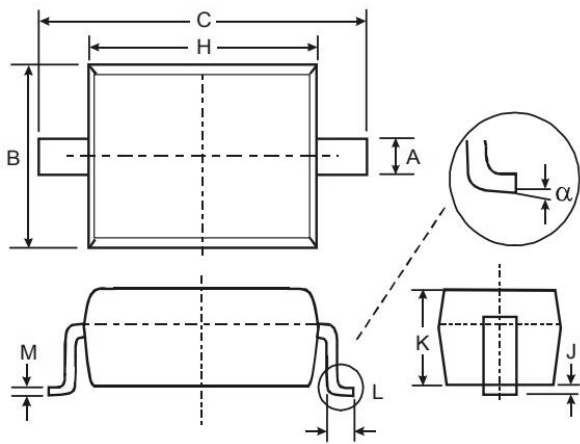

SYMBOL	MILLIMETERS	
	MIN	MAX
A	0.25	0.35
B	1.20	1.40
C	2.40	2.70
H	1.60	1.80
J	0.01	0.15
K	0.80	1.00
L	0.20	0.40
M	0.08	0.15
α	0°	8°