

规格书 Specification

品名
Model name

HNR-1407

PROPRIETARY
Huaneng Electronics co.,Ltd.

CONFIDENTIAL
Huaneng Electronics co.,Ltd.

Version #	Spec V1.0
制作日期 Date	2018/5/4
准备 Prepared	Yang shu yin Acoustic specialist,R&D Dept.
审核 Approved	Zhang chang hua Executive Manager,R&D Dept.



江苏华能电子有限公司

*Components Operating Div.
Huaneng Electronic co., Ltd.*

1.适用范围：本规范适用于HNR-1407 蜂鸣器。

This specifications apply the HNR-1407 buzzer.

2.基本规格/General specification

项目/Item	规格/Spec	条件/Condition	
1	额定电压 Rated voltage	12VAC	
2	工作电压 Operation voltage	1~30VAC	
3	声压 Sound Pressure Level=SPL	Min 85dB	
4	振荡频率 Oscillation frequency	4000±500Hz	
5	电流 Mean Current Consumption	Max 2 mA	
6	工作温度范围 Range of operation temperature	-20~+60℃	声压≥80dB SPL≥80dB
7	保存温度范围 Range of preservation temperature	-30~+70℃	
8	引线强度 Terminal strength	10N	拉负荷方向的终端轴 Pull load on the direction of the terminal axis
9	外部尺寸 Externals size	Φ14.1*7	参阅附图 Refer to the attached drawing
10	重量 Mass	1.3g	

☆标准状态：常温（15~35℃），湿度（25~85%相对湿度），空气压力（860~1060hpa）

在假设的情况判断，测试是一基本状态下进行。

Standard State: Ordinary Temp(15~35℃), Humidity(25~85%RH), Air pressure(860~1060hPa)

In case of doubtful judgment, the test is re-performed under Basic State.

☆基本情况：温度。（20±2℃），湿度（60~70%相对湿度），空气压力（860~1060hpa）

Basic State: Temp.(20±2℃), Humidity(60~70%RH), Air pressure(860~1060hPa)

<标准驱动电路>/<Standard Drive Circuit>

<标准测试治具>/<Standard Test Fixture>

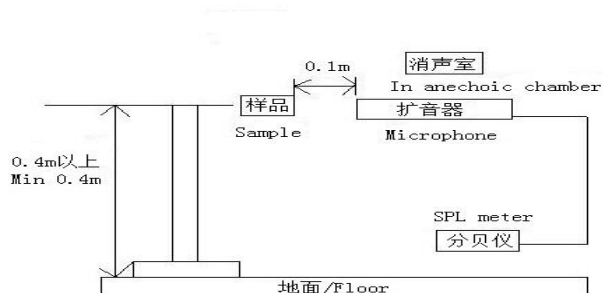
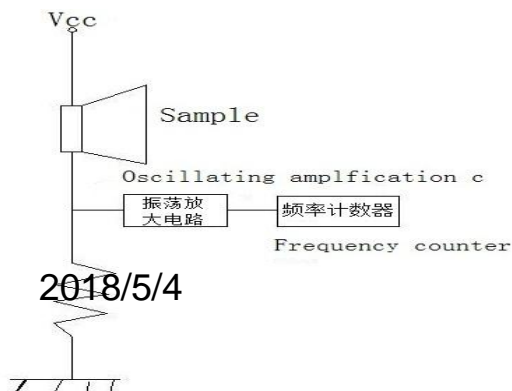

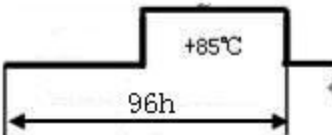
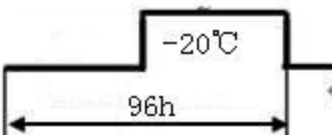
项目/Item		试验条件/Test condition	判断标准/Criteria	引用规格
1	高温保存试验 High temperature Preservation	+85℃环境下放置24小时 Exposure to +85℃ for 24 hrs.	经过测试,符合规格,没有任何不合格的外观和性能 After the test the part shall meet specifications without any degradation.	
2	低温保存试验 Low temperature preservation	-20℃环境下放置24小时 Exposure to -40℃ for 24 hrs.		
3	高温试验 High temperature Shock			
4	低温试验 Low temperature Shock			
5	常温寿命试验 Ordinary Temp. Life	常温 (25℃ ±10℃) 电压12VAC连续测试48小时 Driving the sounder at 12VAC for 48hrs in the room temperature (25℃ ±10℃)		
6	高温寿命试验 High Temp. Life	高温 (+85℃) 电压12VAC连续测试2小时 Driving the sounder at 12VAC for 2hrs in the low temperature (+85℃)		
7	低温寿命试验 Low Temp. Life	低温 (-20℃) 电压12VAC连续测试2小时 Driving the sounder at 12VAC for 2hrs in the low temperature (-20℃)		
8	端子拉力试验 Lead strength	10N的拉力在端子上拉10±1秒 Pull load on the direction of the terminal axis for 10±1 sec.		
9	跌落试验 Free drop	70cm高自由掉落到厚40mm的木板上, 每个方向一次 Free drop, 70cm height, on wood board (t40mm) X, Y, Z 3Direction 1time each, total 3times.	排除弯曲的针 Exclude bending of Pin	
10	端子可焊性试验 Solderability	260±5℃焊接温度。时间: 5±0.5sec。 Soldering into solderbath:Solder Temp. 260±5℃ Soaking Time: 5±0.5sec	端子95%必须覆盖着焊料 95% surface of lead pins must be covered with fresh solder and no soldering holes Should be found	

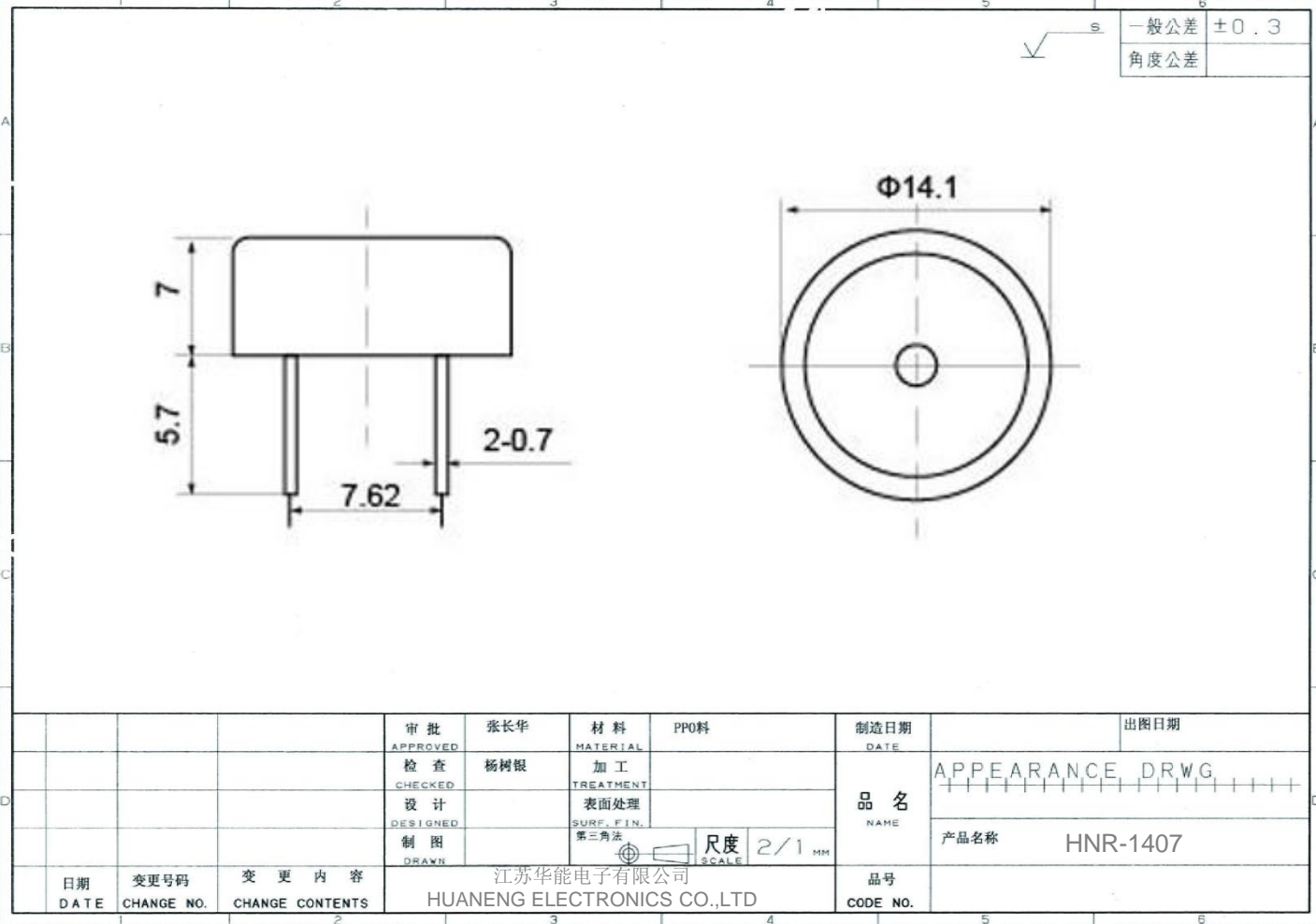

产品特征图

