

MAPX	MODIFICATION	DATE
------	--------------	------

NOTES:

1. HOUSING: SEE NOTES, UL94V-0 .
TERMINAL: SEE NOTES.
SHELL: SEE NOTES.

SPECIFICATION:

1. ELECTRICAL CHARACTERISTIC:
CONTACT RESISTANCE: 30MΩ MAX
DIELECTRIC WITHSTANDING VOLTAGE: 500V AC FOR 1MIN
INSULATION RESISTANCE: 1000MΩ MIN
2. MECHANICAL CHARACTERISTIC:
INSERTION FORCE: 35N(3.57KGF) MAX
EXTRACTION FORCE: 10~35N(1.02~3.57KGF) MIN
DURABILITY: 1500 CYCLES EXTRACTION FORCE:10~35N
5000 CYCLES MIN
3. ENVIRONMENTAL:
OPERATING TEMPERATURE: -55°C+85°C
4. Contact finish:
01:Selective Gold Flash
02:Selective Gold 3U"
03:Selective Gold 5U"
04:Selective Gold 15U"
05:Selective Gold 30U"

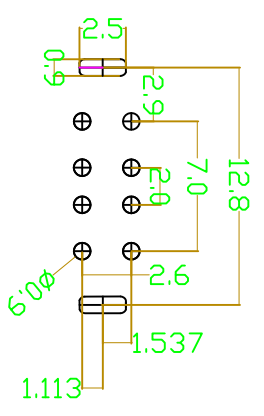
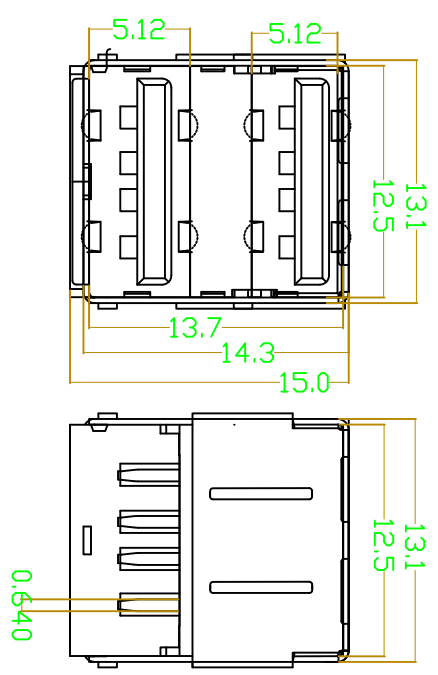
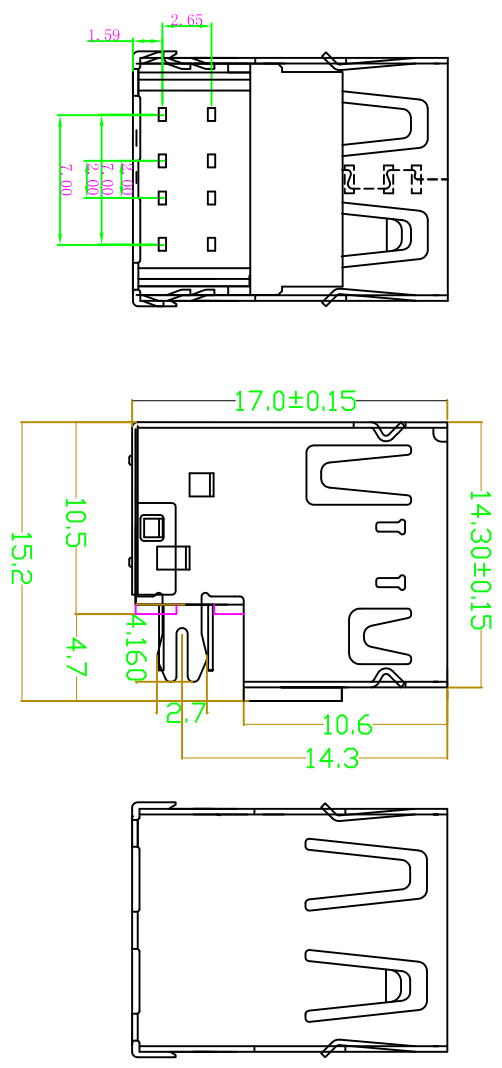

RECOMMENDBD P.C.B PATTBRN LAY OUT

深圳市精拓金电子有限公司

产品图
PRODUCT CHART DWG

公差一览表 TOLERANCE UNLESS OTHERWISE		单位 UNITS	MM	制图 DRAWING	Z-Y-B	制图料号 PRODUCT PART NO.	
X	±0.25	X	±5.°	审核		产品名称 PRODUCT NO.	USB AF双层沉板10.5直边
X	±0.20	X	±2.°	日期	2012.06.10	角法 VIEW	版本 VER
.XX	±0.15	.XX	±1.°	核准			AO
.XXX	±0.10	.XXX	±0.5°	APPD			