

MAPX	MODIFICATION	DATE
------	--------------	------

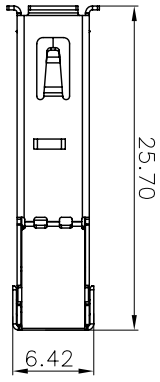
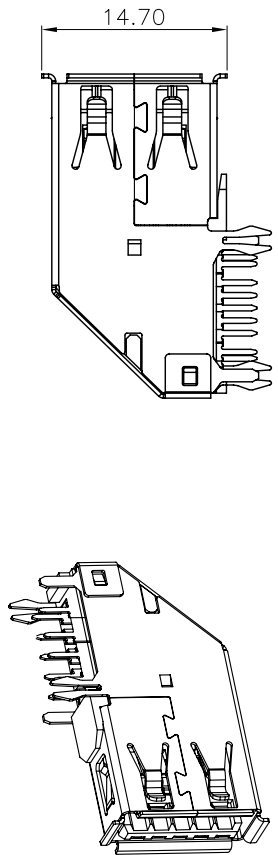

Pin Number	Signal Name	Pin Number	Signal Name
1	VBUS	5	SSRX-
2	D-	6	SSRX+
3	D+	7	GND
4	GND	8	SSTX-
Shell	Shield	9	SSTX+

SPECIFICATIONS:
 Contact current Rating:
 1.8 Amperes for pin1&pin4,
 0.25 Amperes other contacts
 Dielectric Withstanding Voltage:AC 100V(RMS)
 Insulation resistance:100MegoHms Minimum.
 Contact Resistance:
 30mΩ Max for pin1&pin4
 50mΩMax for other contacts
Mechanical Characteristics:
 Mating Force:35 Newtons,Maximum
 Umating Force:10 Newtons,Minimum.
 8N Min After Durability

MATERIAL:
 Housing: PBT
 Contact: copper alloy(T=0.25mm)
 Shell: SUS

PLATING:
 Contact: Au Plated on contact area
 Tin Plated on solder area
 Nickel underplating over all
 Shell: Nickel Plated
 operating Temperature:--55*to+85*.

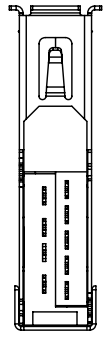
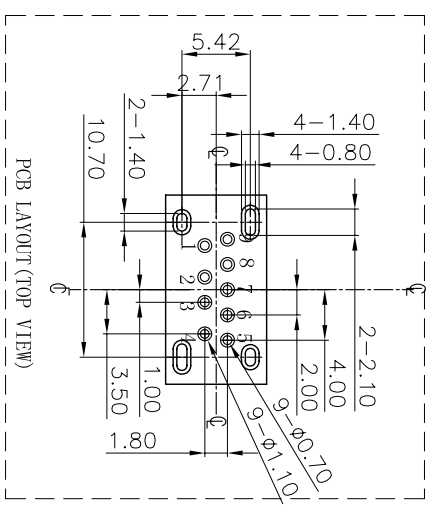
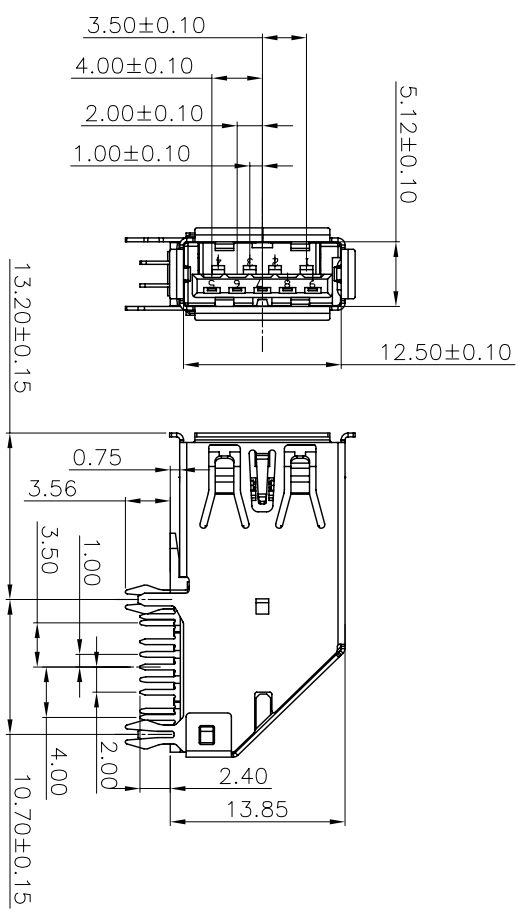

产品图
 PRODUCT CHART DWG
 公差一覽表
 TOLERANCE UNLESS OTHERWISE

深圳市精拓金电子有限公司

公差一覽表	公差	OTHER	公差	公差	公差	公差	公差	公差	公差	公差
X	±0.35	X	±5°							
X	±0.30	X	±2°							
XX	±0.20	XX	±1°							
XXX	±0.10	XXX	±0.5°							

单位	MM	制图	GAVIN	制料号	USB 3.0 AF SIDE
比例	1:1	审核	郭治富	产品名称	USB 3.0 AF SIDE
日期	2015-07-16	核准	黄国荣	版本	AD
DATE		APPD		角法	
				VER	