

MAPX	MODIFICATION	DATE
------	--------------	------

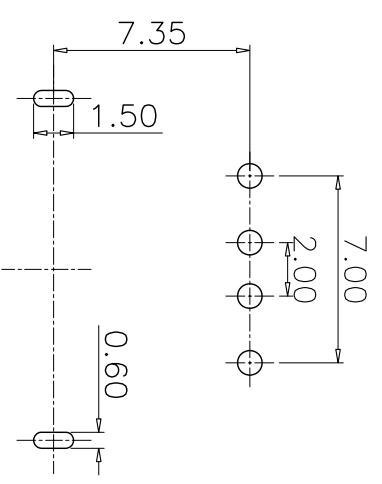

PCB HOLES(THE PATTERN SIDE)
NOTE:GENERAL TOLERANCE:±0.1mm

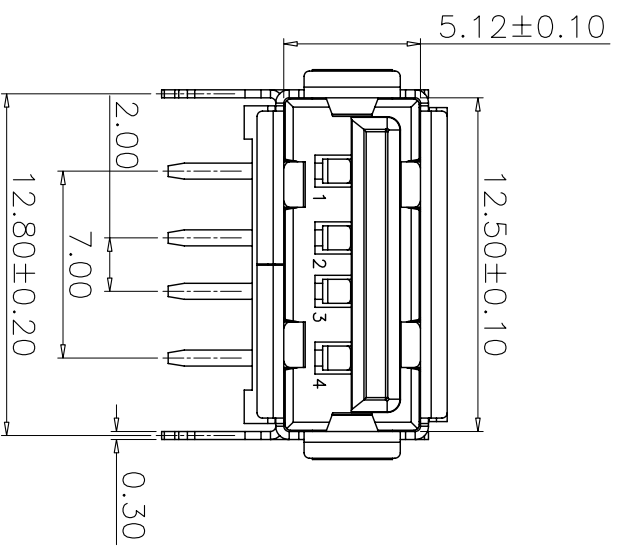
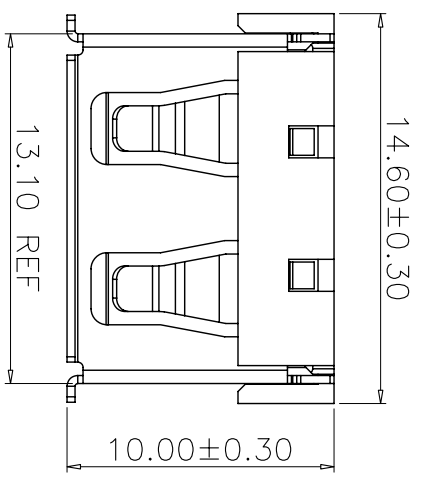
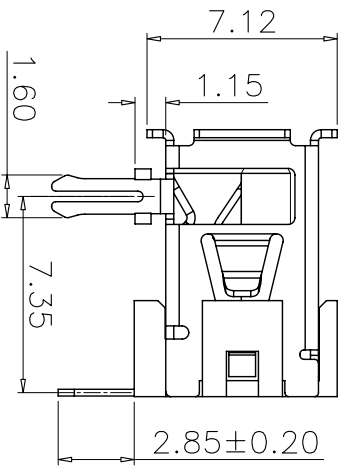

- NOTES:
- HOUSING: SEE NOTES, TERMINAL: SEE NOTES, SHELL: SEE NOTES.
 - ELECTRICAL CHARACTERISTIC: CONTACT RESISTANCE: 30MΩ MAX DIELECTRIC WITHSTANDING VOLTAGE: 500V AC FOR 1MIN INSULATION RESISTANCE: 1000MΩ MIN
 - MECHANICAL CHARACTERISTIC: INSERTION FORCE: 35N(3.57KGF) MAX EXTRACTION FORCE: 10~35N(1.02~3.57KGF) MIN DURABILITY: 1500 CYCLES EXTRACTION FORCE:10~35N 5000 CYCLES MIN 5000 CYCLES EXTRACTION FORCE:3~35N
 - ENVIRONMENTAL: OPERATING TEMPERATURE: -55°C+85°C
 - Contact finish:
 - 01:Selective Gold Flash
 - 02:Selective Gold 3U"
 - 03:Selective Gold 5U"
 - 04:Selective Gold 15U"
 - 05:Selective Gold 30U"

产品图
公差一览表

深圳市精拓金电子有限公司

PRODUCT CHART DWG	单位	MM	制图	Z-Y-B	制图料号	USB A/F 10.0-B-006
TOLERANCE UNLESS OTHERWISE	UNITS		DRAWING		PRODUCT PART NO	
X ±0.15 X ±5.°	X	1:1	审核		产品名称	USB A/F 10.0 (前两脚有边)
X ±0.10 X ±2.°	X		CHD		PRODUCT NO	
.XX ±0.05 .XX ±1.°	.XX		核准		角法	版本
.XXX ±0.03 .XXX ±0.5°	.XXX		APPD		VIEW	VERB
	日期	2010.05.06				A0
	DATE					