

MAPX	MODIFICATION	DATE
------	--------------	------

NOTES:

1. HOUSING: SEE NOTES.  
 TERMINAL: SEE NOTES.  
 SELL: SEE NOTES.

SPECIFICATION:

- ELECTRICAL CHARACTERISTIC:  
 CONTACT RESISTANCE: 30MΩ MAX  
 DIELECTRIC WITHSTANDING VOLTAGE: 500V AC FOR 1MIN  
 INSULATION RESISTANCE: 1000MΩ MIN
- MECHANICAL CHARACTERISTIC:  
 INSERTION FORCE: 35N(3.57KG) MAX  
 EXTRACTION FORCE: 10~35N(1.02~3.57KG) MIN  
 DURABILITY: 1500 CYCLES EXTRACTION FORCE: 10~35N  
 3000 CYCLES MIN  
 5000 CYCLES EXTRACTION FORCE: 3~35N
- ENVIRONMENTAL:  
 OPERATING TEMPERATURE: -55°C~85°C
- Contact finish:  
 01: Selective Gold Flash  
 02: Selective Gold 30"  
 03: Selective Gold 50"  
 04: Selective Gold 150"  
 05: Selective Gold 300"

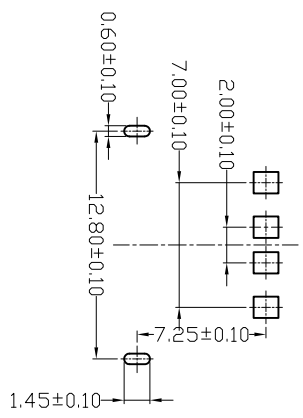
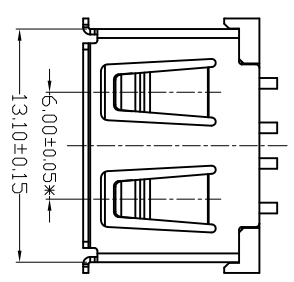

FRONT EDGE OF CONNECTOR  
PCB LAYOUT

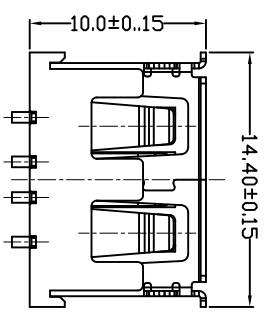
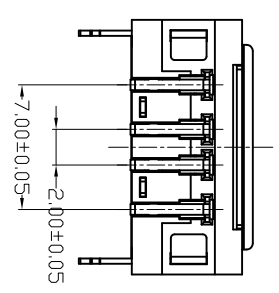
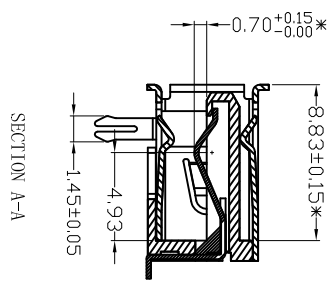
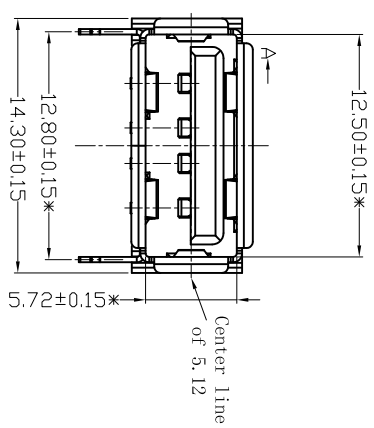
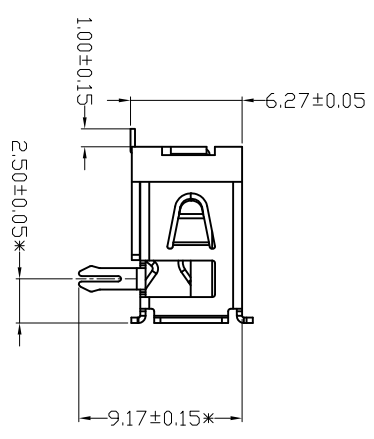

产品图  
PRODUCT CHART DWG

深圳市精拓金电子有限公司

公差一览表		单位	MM	制图	Z-Y-B	制图料号	
TOLERANCE UNLESS OTHERWISE		UNITS		DRAWING		PRODUCT PART NO.	
X ±0.25	X ±5°	SCALE	1:1	审核		USB A/F SMT (10.0)有卷边	
X ±0.20	X ±2°	日期	2012.06.15	核准		角法	版本
XX ±0.15	XX ±1°	DATE		APPD		VER	AD
XXX ±0.10	XXX ±0.5°						

G 1 2 3 4 5 6 7 8 9 10 G  
 F  
 E  
 D  
 C  
 B  
 A