

MAPX	MODIFICATION	DATE
------	--------------	------

NOTES:
 1. HOUSING: SEE NOTES, UJ94V-0.
 TERMINAL: SEE NOTES.
 SHELL: SEE NOTES.

SPECIFICATION:
 1. ELECTRICAL CHARACTERISTIC:
 CONTACT RESISTANCE: 30MΩ MAX
 DIELECTRIC WITHSTANDING VOLTAGE: 500V AC FOR 1MIN
 INSULATION RESISTANCE: 1000MΩ MIN
 2. MECHANICAL CHARACTERISTIC:
 INSERTION FORCE: 35N(3.57KGF) MAX
 EXTRACTON FORCE: 10~35N(1.02~3.57KGF)MIN
 DURABILITY: 1500 CYCLES EXTRACTON FORCE:10~35N
 5000 CYCLES MIN
 5000 CYCLES EXTRACTON FORCE:3~35N

3. ENVIRONMENTAL:
 OPERATING TEMPERATURE: -55°C+85°C
 4. Contact finish:
 01:Selective Gold Flash
 02:Selective Gold 3U"
 03:Selective Gold 5U"
 04:Selective Gold 15U"
 05:Selective Gold 30U"

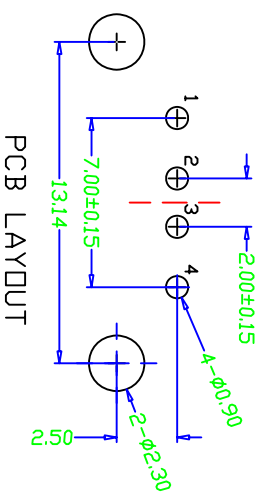
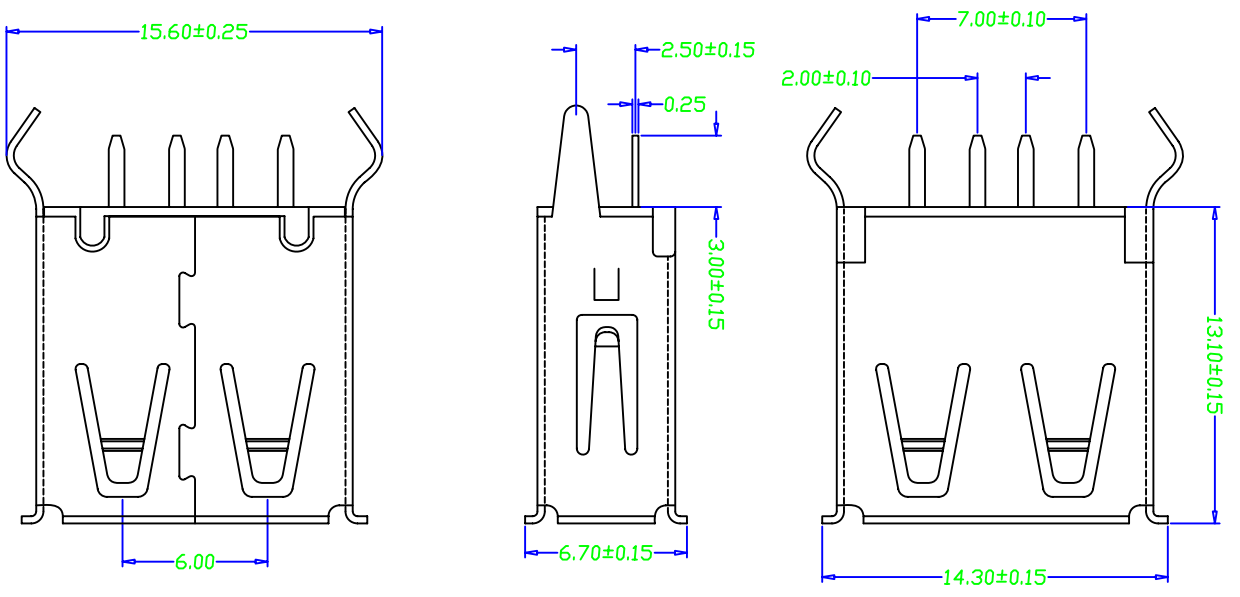

产品图
PRODUCT CHART DWG

深圳市精拓金电子有限公司

公差一览表		单位		制图		制图料号	
TOLERANCE UNLESS OTHERWISE	UNITS	MM	DRAWING	Z-Y-B	PRODUCT PART NO.		
X. ±0.25	X.	±5°	SCALE	1:1	PRODUCT NAME	USB A/F 180度插板式有边 (13.1)	
X. ±0.20	X.	±2°	DATE	2014.07.24	审核	角法	版本
XX. ±0.15	XX.	±1°	APRD	核准	VIEW	AD	
XXX. ±0.10	XXX.	±0.5°					

