

MAPX	MODIFICATION	DATE
------	--------------	------

NOTES:  
 1. HOUSING: SEE NOTES, UJ94V-0.  
 TERMINAL: SEE NOTES.  
 SHELL: SEE NOTES.

SPECIFICATION:

- ELECTRICAL CHARACTERISTIC:  
 CONTACT RESISTANCE: 30MΩ MAX  
 DIELECTRIC WITHSTANDING VOLTAGE: 500V AC FOR 1MIN  
 INSULATION RESISTANCE: 1000MΩ MIN
- MECHANICAL CHARACTERISTIC:  
 INSERTION FORCE: 35N(3.57KGF) MAX  
 EXTRACTION FORCE: 10~35N(1.02~3.57KGF)MIN  
 DURABILITY: 1500 CYCLES EXTRACTION FORCE: 10~35N  
 5000 CYCLES MIN  
 5000 CYCLES EXTRACTION FORCE: 3~35N
- ENVIRONMENTAL:  
 OPERATING TEMPERATURE: -55°C+85°C
- Contact finish:

- Selective Gold Flash
- Selective Gold 3U"
- Selective Gold 5U"
- Selective Gold 15U"
- Selective Gold 30U"

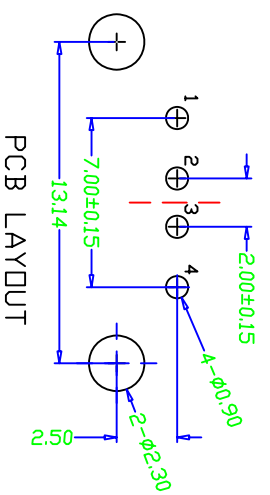
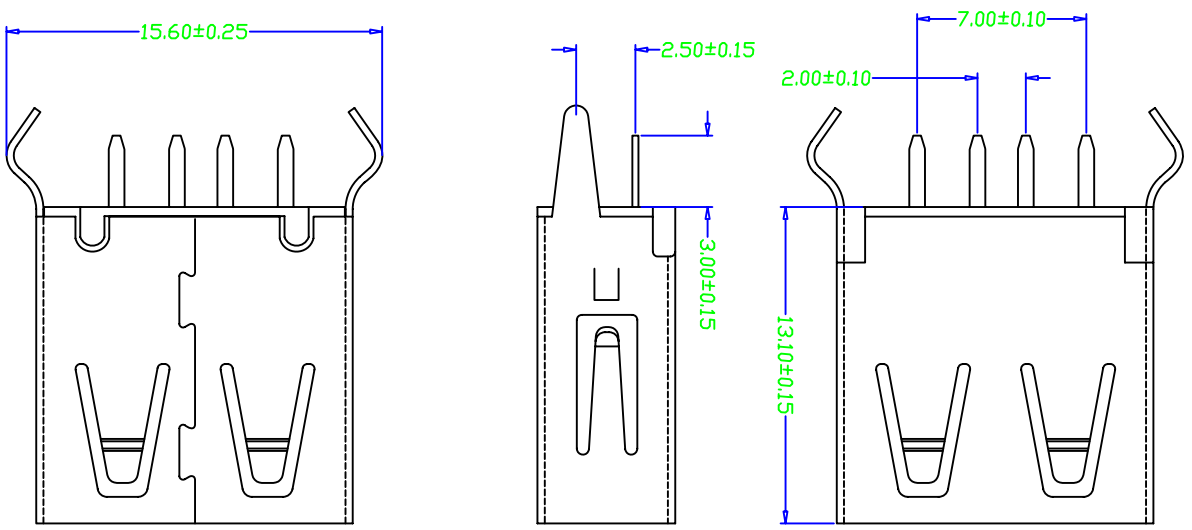

产品图  
 PRODUCT CHART DWG

深圳市精拓金电子有限公司

公差一览表  
 TOLERANCE UNLESS OTHERWISE

X	±0.25	X	±5°
X	±0.20	X	±2°
XX	±0.15	XX	±1°
XXX	±0.10	XXX	±0.5°

单位	MM	制图	Z-Y-B	制料号	
UNITS	MM	DRAWING	Z-Y-B	PRODUCT PART NO.	
比例	1:1	审核		产品名称	USB A/F 180度插板式无边 (13.1)
SCALE	1:1	CHKD		PRODUCT NO.	
日期	2014.07.24	核准		角法	
DATE	2014.07.24	APRD		VER	版本
					AD