

Positive Temperature Coefficient (PTC) Data Sheet

Features

- Holding current from 1.0A to 2.0A
- Radial leaded devices.
- High voltage surge capabilities
- Flame retardant epoxy polymer insulating material meets UL94 V-0 requirement.
- Available in lead-free version.
- Meets MSL level 1, per J-STD-020



Dimensions (Unit: mm)

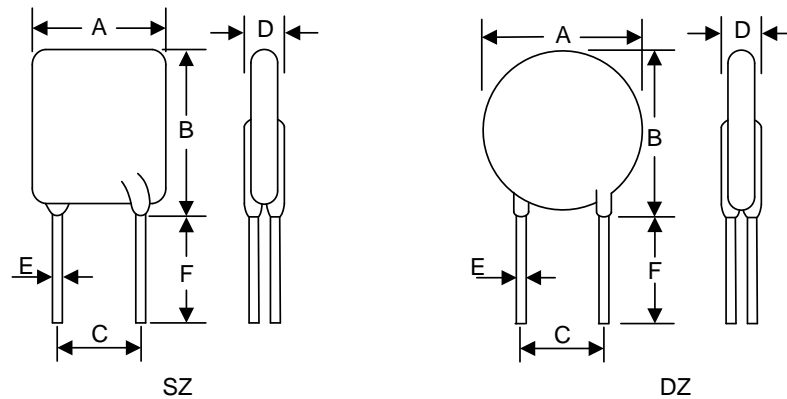

Part Number	A	B	C	D	E	F	Style.
	Max.	Max.	±0.5	Max.	Typ.	Min.	
BK250-1000	21.1	23.6	10.2	4.6	0.8	7.6	DZ
BK250-1500	21.0	27.5	10.2	4.6	0.8	7.6	SZ
BK250-2000	26.2	32.8	10.2	4.6	0.8	7.6	SZ

Electrical Characteristics

Part Number	I_H	I_T	V_{MAXI}	I_{MAX}	R_{MAX}	R_{MIN}	$Pd_{typ.}$
	(A)	(A)	(V _{AC})	(A)	(Ω)	(Ω)	(W)
BK250-1000	1.0	2.0	250	10	0.8	0.3	1.0
BK250-1500	1.5	3.0	250	10	0.6	0.2	1.0
BK250-2000	2.0	4.0	250	10	0.4	0.1	1.0

- I_H = Hold current: maximum current device will pass without tripping in 25°C still air.
- I_T = Trip current: minimum current at which the device will trip in 25°C still air.
- V_{MAXI} = Maximum interrupt voltage device can withstand without damage at rated current.
- I_{MAX} = Maximum fault current device can withstand without damage at rated voltage.
- R_{MAX} = Maximum resistance of device in initial (un-soldered) state.
- R_{MIN} = Minimum resistance of device in initial (un-soldered) state.
- $Pd_{typ.}$ = Typical power dissipation from device when in the tripped state at 25°C still air.

Thermal Derating Chart – I_H (A)

Part Number	Maximum Ambient Operating Temperatures (°C)								
	-40	-20	0	25	40	50	60	70	85
BK250-1000	1.55	1.37	1.19	1.00	0.82	0.73	0.64	0.55	0.41
BK250-1500	2.40	2.10	1.80	1.50	1.30	1.15	1.02	0.88	0.66
BK250-2000	3.10	2.74	2.38	2.00	1.64	1.46	1.28	1.10	0.82

Typical Time-to-Trip Charts @25°C

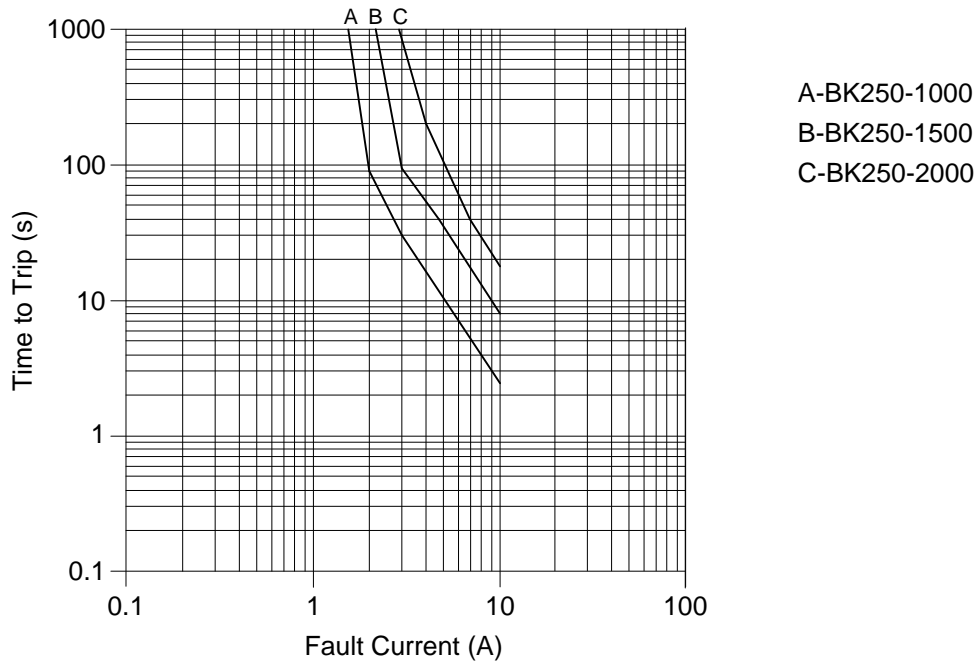

Storage Recommendations

- Storage Temperature: -10°C~+40°C
- Relative Humidity: ≤80%RH
- Keep away from corrosive atmosphere and sunlight.
- Period of Storage: 1 year.

Wave Soldering Recommendation Parameters

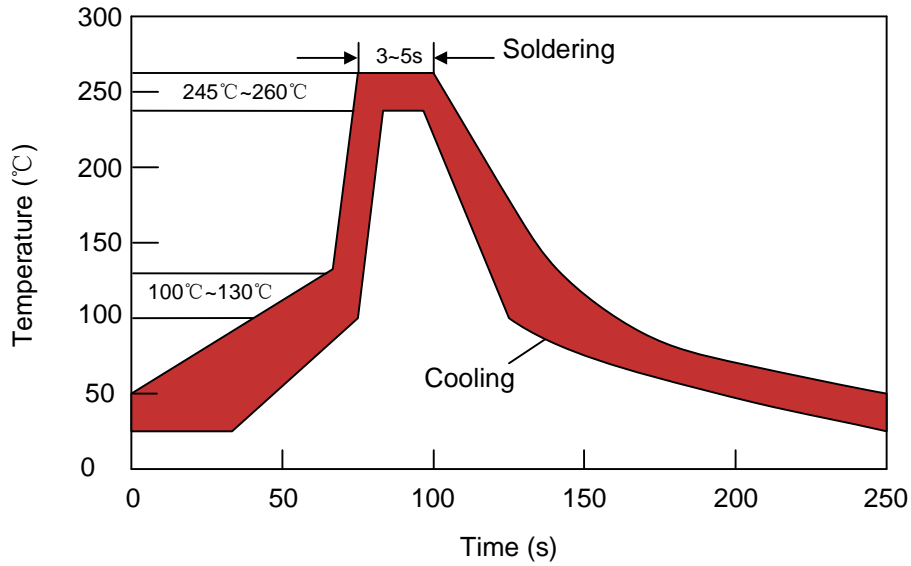

Items	Conditions
Pre-Heating Zone	Refer to the condition recommended by the flux manufacturer. Maximum ramping rate should not exceed 4°C/sec.
Soldering Zone	Maximum solder temperature should not exceed 260°C
Cooling Zone	Forced cooling

Manual Soldering Recommendation Parameters

Items	Conditions
Soldering condition	The highest power of the manual soldering iron should be 30W or less, soldering temperature should not be higher than 280°C.
Soldering time	The soldering time should be kept within 3 seconds, otherwise it might cause insulation layer cracking, and increased part resistance.
Soldering position	The distance on the leads between the soldering point and bottom of the PPTC body should be equal or greater than 4mm.
Other	The soldering iron should not contact the PPTC body except the leads. If the soldering conditions are kept to lower temperature, less time and larger distance, the outcome of the soldering will be better.

- Notes: 1. Before using the device must be stored in the original bags, if the storage conditions do not guarantee, the device may not be able to meet the given value.
2. The devices can't used for reflow soldering.

Mechanical Characteristics

Items	Specifications	Test Conditions/Methods
Tensile strength	No visible damage	1.0Kgf, 10 seconds
Bending strength	No visible damage	0.5Kgf, 90° , 3 times
Vibration	No visible damage	Freq: 10-55Hz, Amp: 0.75mm, 1min

Reliability Test

Items	Specifications	Test Conditions/Methods
Solder ability	No visible damage, Solder OK, Solder area ≥95%	245±5°C, 2±1s, dipping depth=0.5inch max from the body
Resistance to soldering heat	No visible damage, Electrical OK, $ \Delta R/R0 \leq 50\%$	260±5°C, 10+2/-0s
Damp heat, steady state	No visible damage, Electrical OK, $ \Delta R/R0 \leq 20\%$	40±2°C, 90~95 % RH, total 48Hrs, after 4Hrs test electrical parameter
Temperature cycling	No visible damage, Electrical OK, $ \Delta R/R0 \leq 20\%$	Ta=-10+0/-1°C 30min, Ta=70+1/-0°C 30min, 5cycles, after 1hr test electrical parameter

Packaging

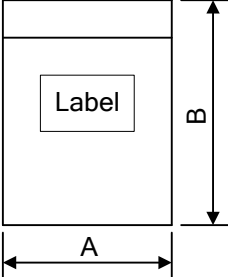
	Dimension AxB (mm)	Quantity
<p>Bag</p> 	150x200	200pcs/bag 800pcs/box
<p>Inner Box</p> 