

注：本板为禁止运输、复制、翻印文件，以及利用其内容进行交流

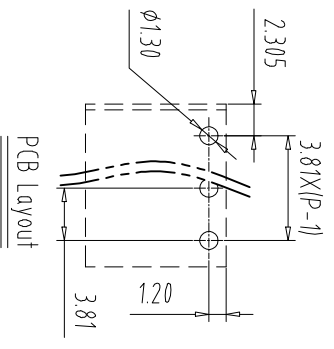
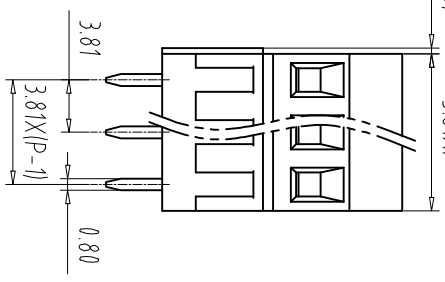
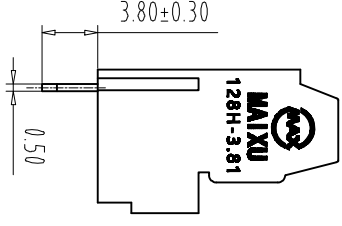
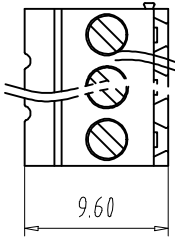

REV	ECN NO.	CONTENT	CHK	DATE

- NOTES1:
UL Standard
1.Rating voltage/current: 150V/12A
2.withstanding voltage: AC1600V/1Min
3.Torque value: M2, 1.77Lb.in
4.Wire range: 30~14AWG
- IEC Standard

Pollution Degree	3	2	2
Overvoltage Category	III	II	II
Rate Impulse Voltage(KV)	2.5	2.5	2.5
Rate Voltage(V)	160V	200V	400V
Rate Current(A)	10A	10A	10A

2. Torque value: M2, 0.2Nm
3.wire range: 1.0mm²

NOTES2:

- 1.Housing: PA66(UL94V-0)
2.Solder Pin: Brass(Sn Plated)
3.Cage: Brass(Ni Plated)
4.Screw: Steel(M2,Zn Plated)

NOTES3:

- 1.Pitch: 3.81mm Poles: 02-24P
2.Stripping length: 5-6mm
3.Operating temperature: -40℃~+105℃
4.RoHS Compliance

How to order

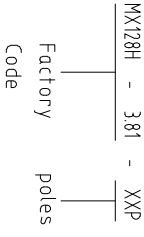

Pitch Range In mm	Nominal Dimension Range In mm					
	Over 6	Over 10	Over 24	Over 30	Over 60	Over 100
TO 6	TO 10	TO 24	TO 30	TO 60	TO 100	TO 150
±0.15	±0.20	±0.30	±0.30	±0.50	±0.70	±1.00
					±1.30	±2*

ITEM	NAME OF PART	NO. OF PART	Q'TY	MATERIAL	NOTE
DWG	CHK	DATE	SCALE	SHEET/OF	1/1
APP	DATE	SCALE	NAME		
			MX128H-3.81-XXP		
			DWGNO.		

CIXI MAIXU ELECTRONICS CO.,LTD
慈溪迈旭电子有限公司