

SECTION A-A

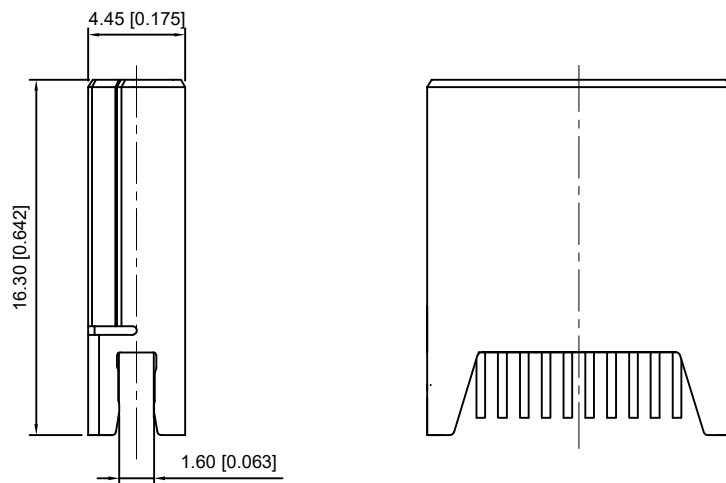
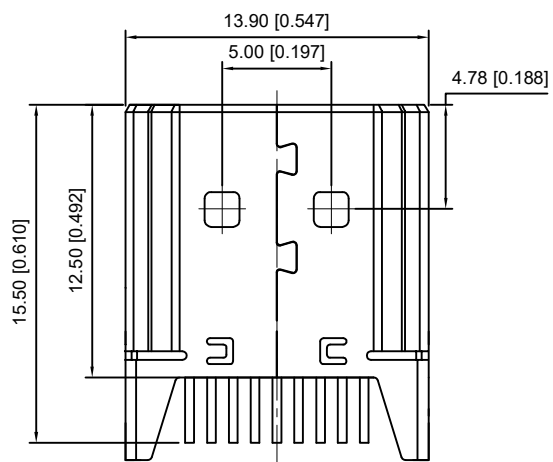

NOTE :

- 1.MATERIAL 材料:
HOUSING 胶壳: LCP,UL94V-0
CONTACT 端子:C5191
SHELL 外壳:BRASS
- 2.FINISH 电镀:
CONTACT 端子: C5191,GOLD OVER NICKEL
SHELL 外壳: BRASS,GOLD FLASH ALL PLATING.
- 3.Electrical parameters 电气参数
Contact Current Rating 触点电流额定值: 0.5A
Voltage Rating 额定电压: 40V AC(RMS)
Operating temperature 工作温度: -25℃ ~ +85℃
- 4.Durability 耐用性: 10000 cycles

A72-16J3-5X5G1

1:AU 1U"
5:AU 15U"
6:AU 30U"

					ANGLAR	±5°	XKIB	DSND		SCALE: N/A	MODEL TYPE: HDMI CONNECTOR	
					L ≤ 4	±0.2		DWN		VIEW:	PART NO.:	
					4 < L ≤ 16	±0.3		CHKD		UNIT: mm/in	DWG NO.:	
					16 < L ≤ 63	±0.4		APPD		SIZE: A4	A72-16J3-5X5G1	
					L > 63	±0.5					WEIGHT	SHEET
REVISIONS					UNSPECIFIED TOLERANCES			XKB INDUSTRIAL PRECISION CO.,LIMITED			1/1	A0
www.helloxkb.com www.helloxkb.cn www.xk-dg.cn												