

Technical requirement

技术要求

Service conditions: - 40 °C ~ 55 °C

使用条件:-40°C~55°C

Rated load: DC 30V 0.5A

额定负荷:DC 30V 0.5A

Contact resistance: ≤ 0.03 Ω

接触电阻:≤0.03Ω

Insulation resistance: ≥ 100m Ω dc250v

绝缘电阻:≥100MΩ DC250V

Withstand voltage: AC 500V (50Hz) / min

耐压:AC 500V(50Hz)/min

Plugging force: 3 ~ 20n

插拔力:3~20N

Mechanical life: 5000 times

机械寿命:5000次

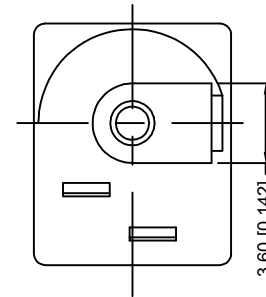
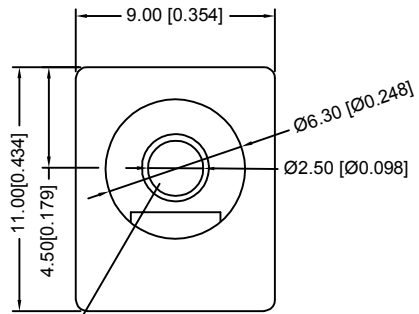

4

线路板按照尺寸示意图

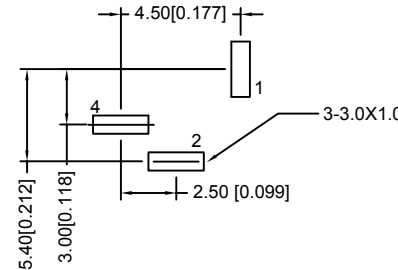

电路结构示意图

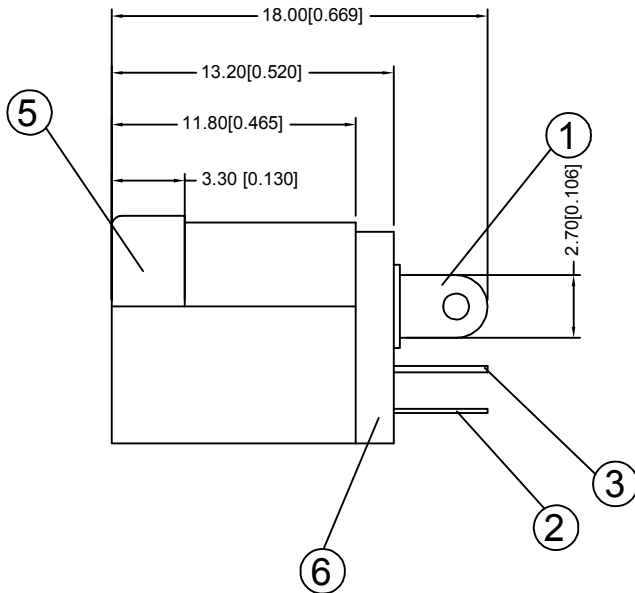
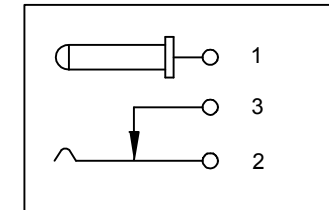

6	Cover plate	1PCS	PA 66	BLACK
5	Pedestal	1PCS	PA 66 (BLACK)	
4	Pin	1PCS	Brass	NI
3	Static contact piece	1PCS	Brass	SN
2	Moving contact piece	1PCS	Spcc	SN
1	Pin pin	1PCS	Brass	SN
ITEM	NAME	PCS	Material Science	Remarks

					ANGLAR	±5°	DSND	SCALE: N/A	MODEL TYPE:			
					L ≤ 4	±0.2	DWN	VIEW:	PART NO.:			
					4 < L ≤ 16	±0.3	CHKD	UNIT: mm/in	DC-012-2.5A-2.5			
					16 < L ≤ 63	±0.4	APPD	SIZE: A4	DWG NO.:			
					L > 63	±0.5				WEIGHT	SHEET	REVISIC
					UNSPECIFIED TOLERANCES			XKB INDUSTRIAL PRECISION CO.,LIMITED			1/1	A0
MARK					DESCRIPTION	DATE	REVISED	APPROVED	www.helloxkb.com www.helloxkb.cn www.xk-dg.cn			
					REVISIONS							