

P.C.B LAYOUT (top view)

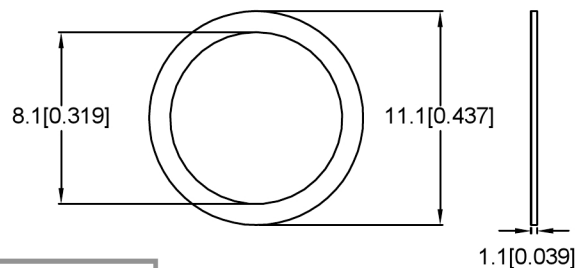
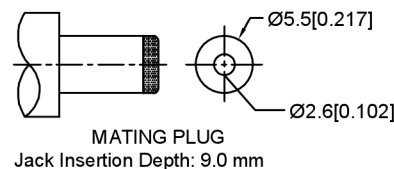
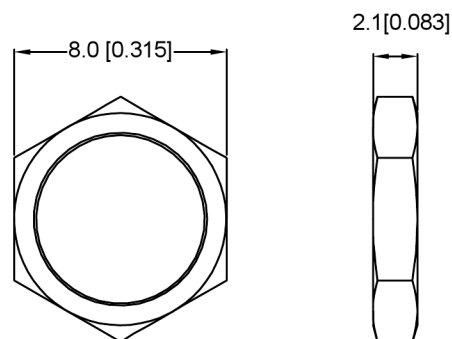
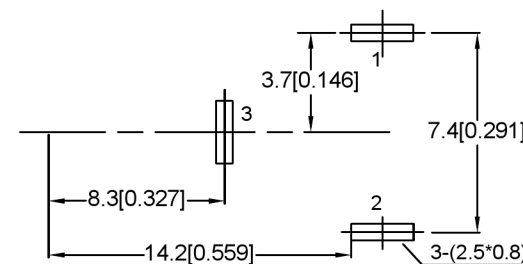

SCHEMATIC	
Model	DC-026LBM
Center Pin	Ø2.0 mm
	Ø2.5 mm

	MATERIAL	PLATING
axle sleeve	Brass	tin
plastic	Pbt	
center pin	Brass	tin
terminal 1	Brass	tin
terminal 2	Brass	tin
terminal 3	Phosphor Bronze	tin

广东星坤科技股份有限公司

Δx		日期
Δx		日期
Δx		日期
MARK	DESCRIPTION	DATE

文件工程章

REVISIONS	DATE	REVISED	APPROVED	UNSPECIFIED TOLERANCES
				ANGULAR ±5°
				L ≤ 4 ±0.2
				4 < L ≤ 16 ±0.3
				16 < L ≤ 63 ±0.4
				L > 63 ±0.5



DSND		SCALE: N/A	MODEL TYPE: DC POWER JACK
DWN		VIEW:	PART NO.: DC-026LBM-5A-2.5
CHKD		UNIT: mm/in	DWG NO.:
APPD		SIZE: A4	

XKB INDUSTRIAL PRECISION CO., LIMITED

WEIGHT	SHEET	REVISIC
	1/1	A0

www.helloxkb.com www.helloxkb.cn www.xk-dg.cn