

P.C.B LAYOUT
TOP VIEW

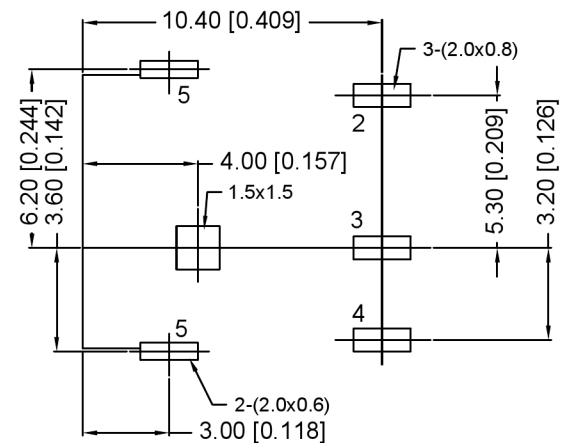

SCHEMATIC

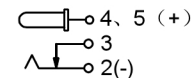

SPECIFICATION

1. Rating : DC 24V 5.0A;
2. Contact resistance : $\leq 0.03\Omega$;
3. Insulation resistance : $\geq 100M\Omega$ (DC250V);
4. Withstand voltage : 500VAC ;
5. Insertion and extraction force : 3-20N;
6. life test : 5,000 cycles .

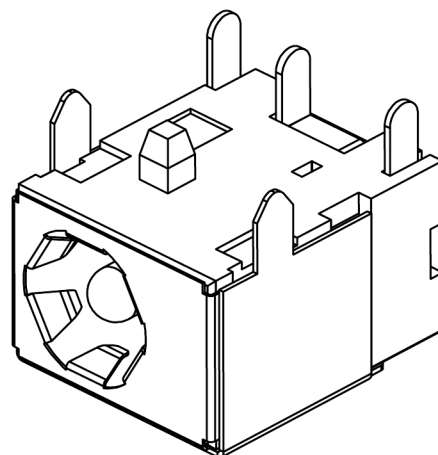
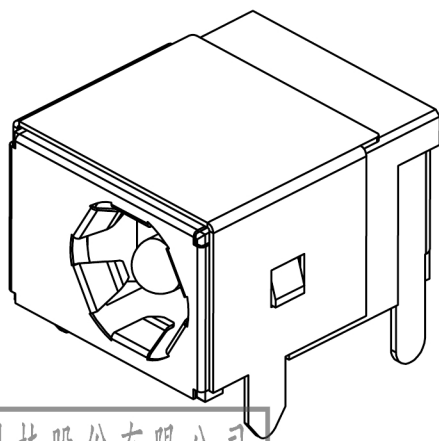

7	COVER	1	SUS301	
6	CONTACT FOOT	1	BRONZE	Ni-Plating
5	PIN	1	H59 BRASS	Ni-Plating
4	CONTACT FOOT	1	BRASS	Ag-Plating
3	CURVE PIECE	1	BRASS	Ag-Plating
2	SPRING PIECE	1	BRONZE	Ag-Plating
1	HOUSING	1	HIGH TEMP THERMOPLASTIC UL-94 VO	
NO.	DESCRIPTION	QTY	MATERIAL	PLATING

广东星坤科技股份有限公司

MARK	DESCRIPTION	DATE	REVISED	APPROVED	UNSPECIFIED TOLERANCES
Δx					ANGLAR ±5°
Δx					L ≤ 4 ±0.2
Δx					4 < L ≤ 16 ±0.3
					16 < L ≤ 63 ±0.4
					L > 63 ±0.5



DSND		SCALE: N/A	MODEL TYPE: DJ JACK
DWN		VIEW:	PART NO.: DC-044B-5A-2.5
CHKD		UNIT: mm/in	DWG NO.:
APPD		SIZE: A4	
XKB INDUSTRIAL PRECISION CO., LIMITED			WEIGHT
			SHEET
			REVISIC
			1/1
			A0

文件工程章

www.helloxkb.com www.helloxkb.cn www.xk-dg.cn