

MODEL NO.	PJ-3020	PJ-3021	PJ-3022	PJ-3023
SCHMATIC				

SPECIFICATION:

- 1.RATING:DC30V 0.5A;
- 2.CONTACT RESISTANCE:≤50mΩ;
AFTER LIFE TEST:≤100mΩ;
- 3.INSULATION RESISTANCE:≥100mΩ(DC250V);
AFTER LIFE TEST:≤50mΩ;
- 4.WITHSTAND VOLTAGE:500V AC;
- 5.INSERTION AND EXTRACTION FORCE:3-30N;
- 6.LIFE TEST:5,000 CYCLES Min

	MATERIAL	PLATING
terminal 1	Phosphor Bronze	silver
terminal 2	Phosphor Bronze	silver
terminal 3	Phosphor Bronze	silver
terminal 4	Phosphor Bronze	silver
terminal 5	Phosphor Bronze	silver
terminal 6	Phosphor Bronze	silver
terminal 10	Phosphor Bronze	silver
plastic	High Temp. Thermoplastic	

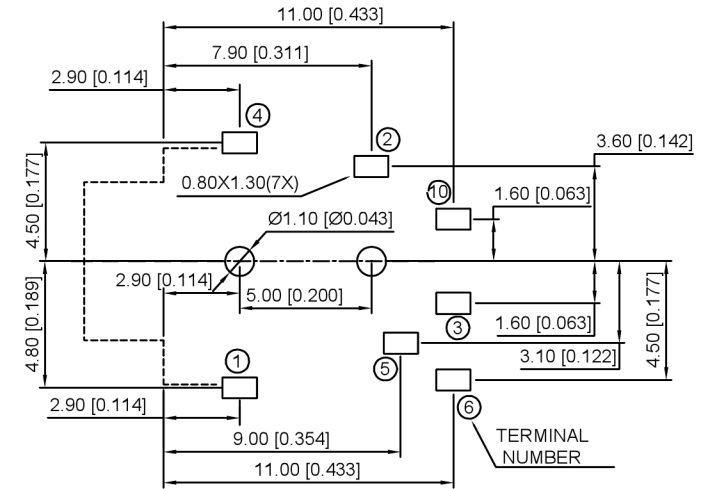

PCB LAYOUT
(BOTTOM VIEW)

广东星坤科技股份有限公司

MARK	DESCRIPTION	DATE	REVISIONS
Δx			
Δx			
Δx			

文件工程章

DATE	REVISED	APPROVED	UNSPECIFIED TOLERANCES

ANGLAR	±5°	XKIB	
L ≤ 4	±0.2		
4 < L ≤ 16	±0.3		
16 < L ≤ 63	±0.4		
L > 63	±0.5		
DSND		SCALE: N/A	MODEL TYPE: 3.5 PHONE JACK
DWN		VIEW:	PART NO.: PJ-302X
CHKD		UNIT: mm/in	DWG NO.:
APPD		SIZE: A4	
XKB INDUSTRIAL PRECISION CO., LIMITED			WEIGHT
			SHEET
			REVISIC
			1/1
			A0