

SPECIFICATION

1. Rating : DC 30V 0.5A;
2. Contact resistance: $\leq 0.03\Omega$;
3. Insulation resistance: $\geq 100M\Omega$ (DC250V);
4. Withstand voltage: 500VAC ;
5. Insertion and extraction force: 3-20N;
6. life test: 5,000 cycles.

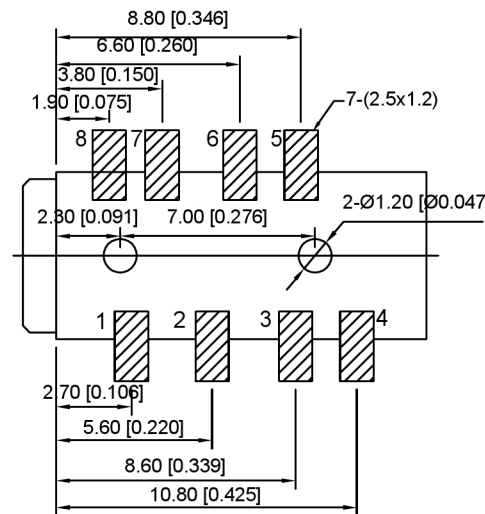

PCB LAYOUT TOP VIEW

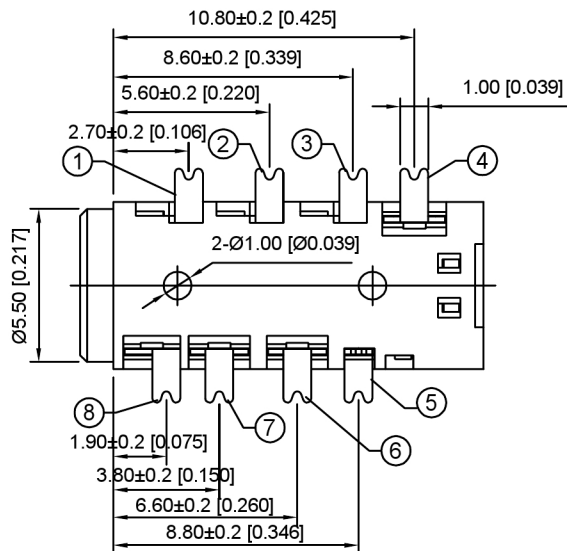
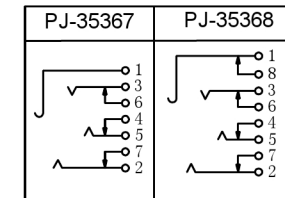
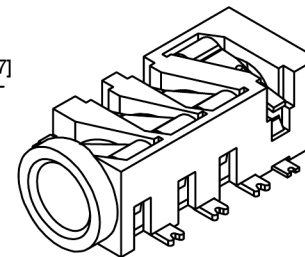

NO.	DESCRIPTION	QTY	MATERIAL	PLATING
1	HOUSING	1	PA9T	
9	SPRING PLATE	1	SUS	
8	TERMINAL 8	1	Phosphor bronze	Ag-Plating
7	TERMINAL 7	1	Phosphor bronze	Ag-Plating
6	TERMINAL 6	1	Phosphor bronze	Ag-Plating
5	TERMINAL 5	1	Phosphor bronze	Ag-Plating
4	TERMINAL 4	1	Phosphor bronze	Ag-Plating
3	TERMINAL 3	1	Phosphor bronze	Ag-Plating
2	TERMINAL 2	1	Phosphor bronze	Ag-Plating
1	TERMINAL 1	1	Phosphor bronze	Ag-Plating

DSND	SCALE: N/A	MODEL TYPE:
DWN	VIEW:	3.5 PHONE JACK
CHKD	UNIT: mm/in	PART NO.: PJ-3536X-X-SMT
APPD	SIZE: A4	DWG NO.: X-PJ-3536X-X-SMT
		WEIGHT
		SHEET 1/1
		REVISIT A0

广东星坤科技股份有限公司

MARK	DESCRIPTION	DATE	REVISIT
Δx			
Δx			
Δx			

文件工程章

REVISIONS	DATE	REVISED	APPROVED	UNSPECIFIED TOLERANCES

ANGULAR	±5°
L ≤ 4	±0.2
4 < L ≤ 16	±0.3
16 < L ≤ 63	±0.4
L > 63	±0.5



XKB INDUSTRIAL PRECISION CO., LIMITED