

SPECIFICATIONS 规范:

1. ELECTRICAL CHARACTERISTICS 电特性:
  - 1-1. RATING 电流: 1.8A (PIN1/5), 0.5A (PIN2/3/4)
  - 1-2. CONTACT RESISTANCE 接触电阻: 30mΩ MAX. (INITIAL)
  - 1-3. DIELECTRIC WITHSTANDING VOLTAGE 耐压介质: 300V AC FOR ONE MINUTE.
  - 1-4. INSULATION RESISTANCE 绝缘电阻: 100MΩ MIN. MEASURED BY 500 VDC
2. MECHANICAL CHARACTERISTICS 力学特性:
  - 2-1. INSERTION FORCE 插入力: 3.6 KGF (MAX)
  - 2-2. WITHDRAWAL FORCE 拔出力: 0.8 KGF (Reference)
3. DURABILITY 拔插周期: 10,000 CYCLES
4. WATER PROOFNESS 水密性: THIS PRODUCT IS BASED ON IPX7(1m,30min)
5. PLUG INTERFACE DIMENSIONS CONFORM TO USB2.0 SPEC.
6. OVALRING 密封圈
  - 6-1. The amount of low molecular siloxanes(D3~D10)jis less than 200ppm
  - 6-2. Hardness of silicone rubber 硅橡胶硬度: 70°
  - 6-3. Horizontal flash 0.1max; Longitudinal flash 0.10max
7. BODY WITH O-RING'S SEAL AREA BURRS IS 0.05mm Max.
8. FOR REFLOW SOLDERING LEAD-FREE PROCESS.
9. PACKAGING: TAPE & REEL.

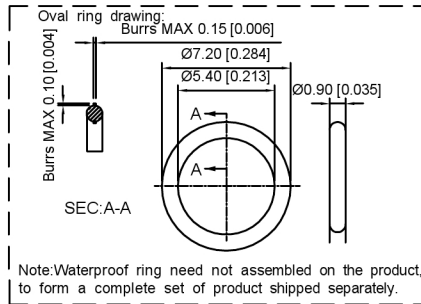
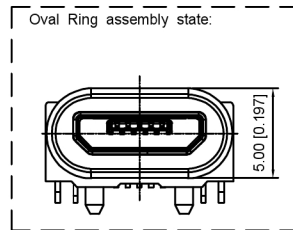
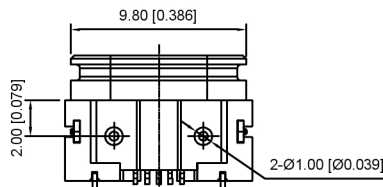
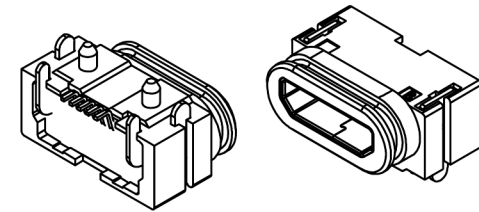
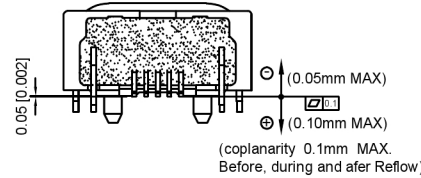
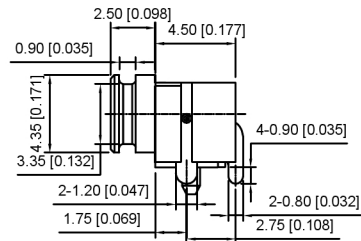
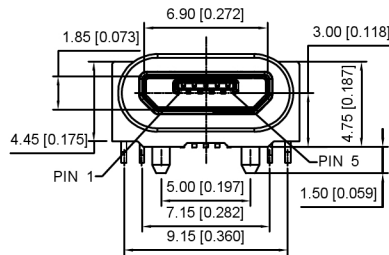

TABLE: ②

料号	Color 颜色
XKQ-281-OG	Gray 灰色

ITEM	PAPT NAME	QTY	MATERIAL	FINISHING
④	Contact	5	C18140H T=0.20	
③	Shell	1	SUS304 T=0.25	Nickel
②	Terminal	2	C2680 T=0.3	
①	Housing	1	HI-TEMP.PLASIC UL 94V-0	BLACK

UNLESS OTHERWISE SPECIFIED, TOLERANCE ON DECIMAL: ±0.3

广东星坤科技股份有限公司

Δx									
Δx									
Δx									
MARK									

DESCRIPTION

REVISIONS

www.helloxkb.com www.helloxkb.cn www.xk-dg.cn

DATE

REVISED

APPROVED

UNSPECIFIED TOLERANCES

ANGLAR	±5°
L ≤ 4	±0.2
4 < L ≤ 16	±0.3
16 < L ≤ 63	±0.4
L > 63	±0.5



XKB INDUSTRIAL PRECISION CO., LIMITED

DSND		SCALE: N/A	MODEL TYPE:	MICRO USB
DWN		VIEW: ④	PART NO.:	XKQ-281-OG
CHKD		UNIT: mm/in	DWG NO.:	U-E-M7SS-Y-0
APPD		SIZE: A4	WEIGHT	

SHEET	1/1	REVISIO	A0
-------	-----	---------	----

文件工程章