

SPECIFICATION:

1. Material

Housing Material: High temperature thermoplastic
 Contact Terminal: High Grade Copper Alloy
 Merallic Shell: Stainless Steel
 Inner Ground Cover Shell: Stainless Steel
 Mid Plate: Stainless Steel

2. Mechanical:

2.1. Mating force: 5-20Nf;
 2.2. Unmating force: Initial: 8-20Nf; Final: 6-20Nf;
 2.3. Durability: 5000 Cycles;

3. Electrical:

3.1. Current Rating: 3A
 3.2. Voltage Rating: 20V Max. ;
 3.3. Dielectric Withstanding

volage: 100Vac, 60S, 10mA;

3.4. Contact resistance: 40m Ohms Max. ;
 3.5. Insulation Resistance: 100M Ohms Min. ;

4. Environmental:

4.1. Operating temperature: -40°C~+85°C;
 4.2. Salt Spray Test: 24H Min. (No oxidation or rust);

U262-16XN-4BC20865

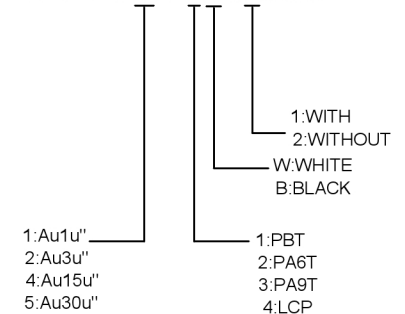

广东星坤科技股份有限公司
 文件工程章

MARK	DESCRIPTION	DATE	REVISED	APPROVED	UNSPECIFIED TOLERANCES
ΔX					ANGULAR ±5°
ΔX					L ≤ 4 ±0.2
ΔX					4 < L ≤ 16 ±0.3
ΔX					16 < L ≤ 63 ±0.4
ΔX					L > 63 ±0.5

DSND	SCALE: N/A	MODEL TYPE: Type-C 3.1
DWN	VIEW:	PART NO.:
CHKD	UNIT: mm/in	DWG NO.: U262-16XN-4BC20865
APPD	SIZE: A4	WEIGHT SHEET REVISION
XKB INDUSTRIAL PRECISION CO., LIMITED		1/1 A0