

PCB LAYOUT

Specifications:

规格:

- 1.Voltage rating:250VAC/DC  
额定电压: 250V AC/DC
- 2.Current rating:3A AC/DC  
额定电流:3A AC/DC
- 3.Withstanding voltage:1000V AC/minute  
耐受电压: ≥1000V AC/分钟
- 4.Temperature range: -25°C~+80°C  
温度范围: -25°C~+80°C
- 5.Insulation resistance:5000MΩMIN  
绝缘电阻: ≥5000MΩ
- 6.Contact resistance:30mΩMax  
接触电阻: ≥30mΩ

Material:

材料:

- 7.Rubber core:PBT UL94V-0  
胶芯: PBT UL94V-0
  - 8.The iron shell:SPCC Terminal half-Gold 15u Matte Tin  
铁壳: SPCC 半金15u雾锡
- B、成品不能有弯针，R角不一致等不良。

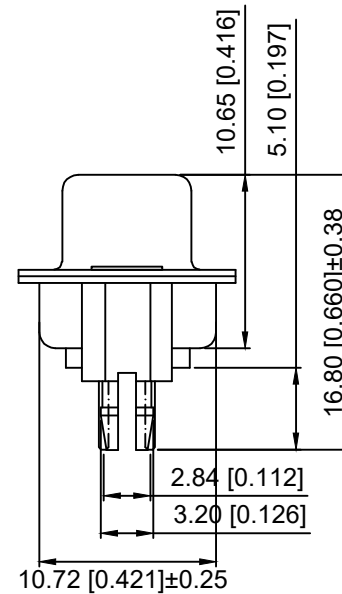
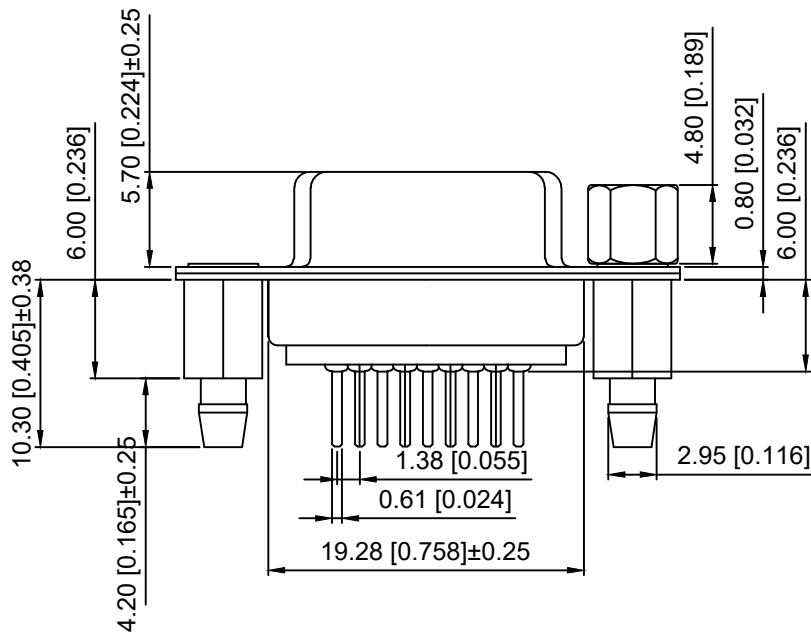

X02 09 F T 17 B X  
① ② ③ ④ ⑤ ⑥ ⑦

- ① Series NO.
- ② Row No.Pin No.XX-09;
- ③ Welding Board Angle :F-Female
- ④ T: Tradtional
- ⑤ Planting Category: 17-Terminal half-Gold 15u Matte Tin
- ⑥ Color:B-BLACK
- ⑦ 5:TYPE-5: 7:TYPE-7

|      |             |               |
|------|-------------|---------------|
| 铆合方式 | TYPE-7:后铆鱼叉 | TYPE-5:铆鱼叉锁螺丝 |
| 图示   |             |               |

|   |             |  |  |             |         |          |                                      |             |             |               |          |
|---|-------------|--|--|-------------|---------|----------|--------------------------------------|-------------|-------------|---------------|----------|
|   |             |  |  | ANGLAR      | ±5°     |          | DSND                                 | SCALE: N/A  | MODEL TYPE: | D-USB         |          |
| ΔX  |             |  |  | L ≤ 4       | ±0.2    |          | DWN                                  | VIEW:       | PART NO.:   | X0209FT17BX   |          |
| ΔX  |             |  |  | 4 < L ≤ 16  | ±0.3    |          | CHKD                                 | UNIT: mm/in | DWG NO.:    | X-X0209FT17BX |          |
| ΔX  |             |  |  | 16 < L ≤ 63 | ±0.4    |          | APPD                                 | SIZE: A4    | WEIGHT      | SHEET         | REVISION |
| MARK  | DESCRIPTION |  |  | DATE        | REVISED | APPROVED | UNSPECIFIED TOLERANCES               |             |             | A0            |          |
| REVISIONS                                     |             |  |  |             |         |          | XKB INDUSTRIAL PRECISION CO.,LIMITED |             |             |               | 1/1      |
| www.helloxkb.com www.helloxkb.cn www.xk-dg.cn |             |  |  |             |         |          |                                      |             |             |               | A0       |