

PCB LAYOUT

Specifications:

规格:

- 1.Voltage rating:250VAC/DC
额定电压: 250V AC/DC
- 2.Current rating:3A AC/DC
额定电流:3A AC/DC
- 3.Withstanding voltage:1000V AC/minute
耐受电压: ≥1000V AC/分钟
- 4.Temperature range: -25°C~+80°C
温度范围: -25°C~+80°C
- 5.Insulation resistance:5000MΩMIN
绝缘电阻: ≥5000MΩ
- 6.Contact resistance:30mΩMax
接触电阻: ≥30mΩ

Material:

材料:

- 7.Rubber core:PBT UL94V-0
胶芯: PBT UL94V-0
 - 8.The iron shell:SPCC Terminal half-Gold 15u Matte Tin
铁壳: SPCC 半金15u雾锡
- B、成品不能有弯针，R角不一致等不良。

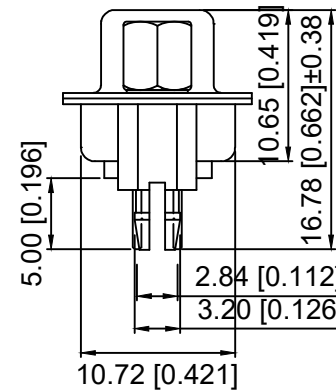
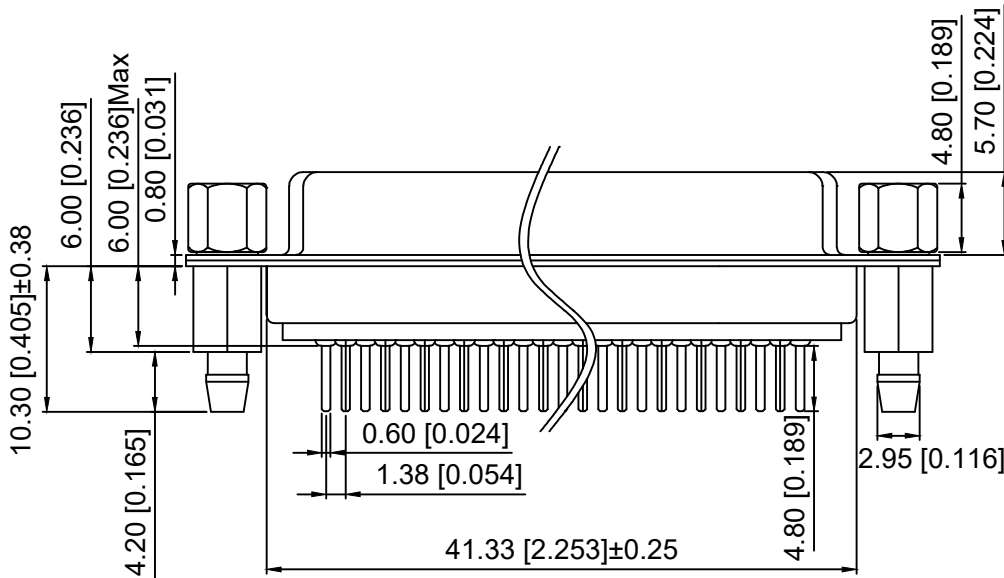

X02 37 F T 17 B 5
① ② ③ ④ ⑤ ⑥ ⑦

- ① Series N0.
- ② Row No.Pin No.XX-37;
- ③ Welding Board Angle -F-Female
- ④ T: Tradutional
- ⑤ Planting Category: 17-Terminal half-Gold 15u Matte Tin
- ⑥ Color:B-BLACK
- ⑦ 5:TYPE-5

铆合方式	TYPE-5:铆鱼叉锁螺丝
图示	

					ANGLAR	±5°		DSND	SCALE: N/A	MODEL TYPE: D-USB
					L ≤ 4	±0.2		DWN	VIEW:	PART NO.: X0237FT17B5
					4 < L ≤ 16	±0.3		CHKD	UNIT: mm/in	DWG NO.: X-X0237FT17B5
					16 < L ≤ 63	±0.4		APPD	SIZE: A4	REVISION
MARK	DESCRIPTION	DATE	REVISED	APPROVED	L > 63	±0.5	XKB INDUSTRIAL PRECISION CO., LIMITED		WEIGHT	SHEET
REVISIONS						UNSPECIFIED TOLERANCES			1/1	A0
www.helloxkb.com www.helloxkb.cn www.xk-dg.cn										