

LEFT SIDE VIEW

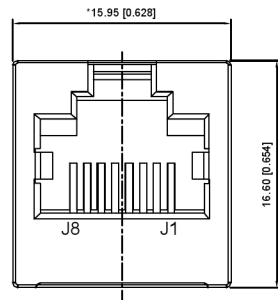

FRONT VIEW

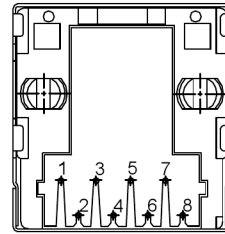

BACK VIEW

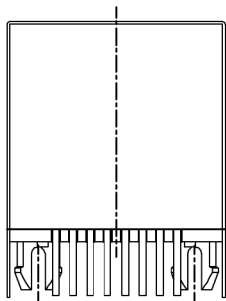
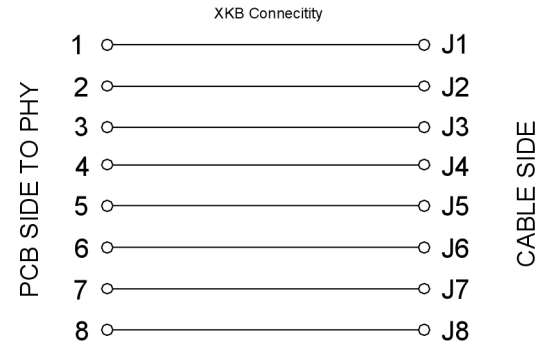

BOTTOM VIEW

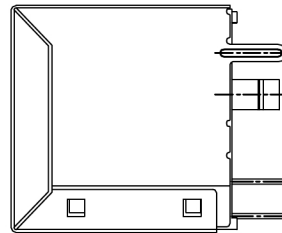

RIGHT SIDE VIEW

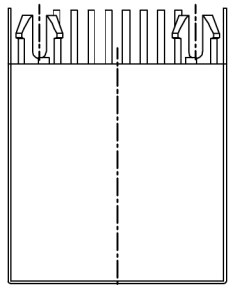

TOP VIEW

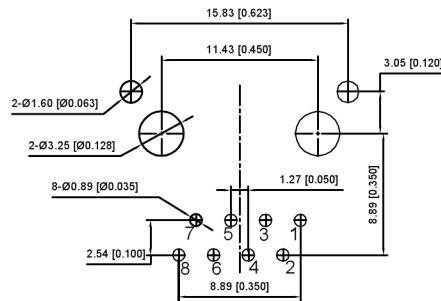

RECOMMENDED PCB LAYOUT
VIEWED FROM COMPONENT SIDE

XKB Connectivity

XKB Connectivity

MATERIAL 材料:

HOUSING 外壳: PBT,UL94V-0,BLACK.

TERMINAL 端子: PHOSPHOR BRONZE ,Ø=0.46MM,
GOLD PLATING ON CONTACT AREA.

SHIELD 保护物:C2680,T=0.20MM,20 MIN NICKEL PLATING
ON ALL AREA.

MECHANICAL 机械:

DURABILITY 耐用性: 750 CYCLES MIN.12.5MM/MINUTE

INSERTION FORCE 插入力: 2.2KG.F MAX

RETENTION STRENGTH 固位力:7.7KG.F BETWEEN JACK AND PLUG

OPERATING TEMPERATURE 工作温度: -40°C~+85°C.

STORAGE TEMPERATURE 储存温度: -40°C~+85°C.

ALL CRITICAL DIMENSIONS WITH "*"

ELECTRICAL 电动:

VOLTAGE 电压:125 VOL TS AC

CURRENT RATING 额定电流:1.5AMP

DIELECTRIC STRENGTH 介电强度:1000 VAC RMS 50HZ OR 60HZ,1MIN

INSULATION RESISTANCE 绝缘电阻:500 MEGA OHMS MIN.INITIAL
AFTER 500V DC FOR 1 MINUTE

CONTACT RESISTANCE 接触电阻:SINGLE TERMINAL 30 MILLIOHMS MAX
INITIAL 50 MILLIOHMS MAX.AFTER
DURABILITY TEST

广东星坤科技股份有限公司

ΔX		日期
ΔX		日期
ΔX		日期
MARK		DESCRIPTION

文件工程章

REVISIONS	DATE	REVISED	APPROVED	DESCRIPTION

www.hellokbc.com www.hellokbc.cn www.xk-dg.cn

ANGLAR	±5°
L ≤ 4	±0.2
4 < L ≤ 16	±0.3
16 < L ≤ 63	±0.4
L > 63	±0.5
UNSPECIFIED TOLERANCES	



DSND	SCALE: N/A	MODEL TYPE:	RJ JACK
DWN	VIEW:	PART NO.:	
CHKD	UNIT: mm/in	DWG NO.:	X05ADGWA3DY1027
APPD	SIZE: A4	WEIGHT	SHEET
XKB INDUSTRIAL PRECISION CO.,LIMITED		1/1	REVISIO
			A0