

TOP VIEW

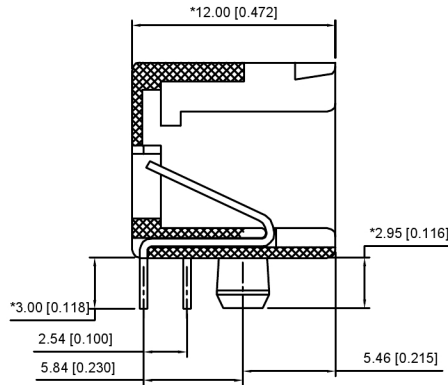

CUTAWAY VIEW

XKB Connectivity

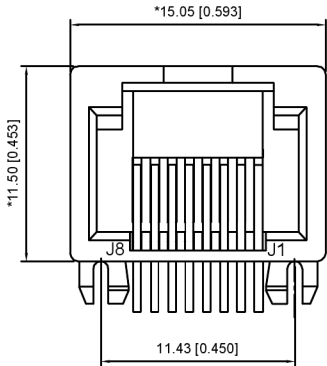
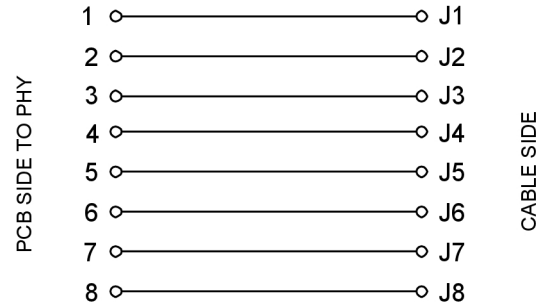

FRONT VIEW

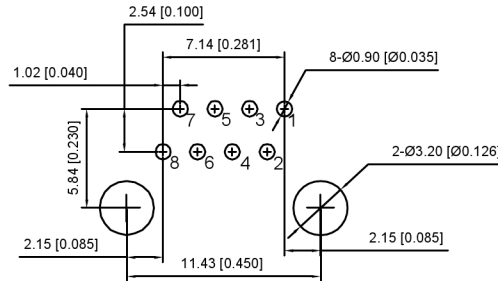

RECOMMENDED PCB LAYOUT
VIEWED FROM COMPONENT SIDE

XKB Connectivity

XKB Connectivity

MATERIAL 材料:

HOUSING 外壳: PBT,UL94V-0,BLACK.
TERMINAL 端子: PHOSPHOR BRONZE, Ø=0.46MM,
GOLD PLATING ON CONTACT AREA.

MECHANICAL 机械:

DURABILITY 耐用性: 750 CYCLES MIN.12.5MM/MINUTE
INSERTION FORCE 插入力: 2.2KG.F MAX
RETENTION STRENGTH 固位力:7.7KG.F BETWEEN JACK AND PLUG
OPERATING TEMPERATURE 工作温度: -40°C~+85°C.
STORAGE TEMPERATURE 储存温度: -40°C~+85°C.
ALL CRITICAL DIMENSIONS WITH "MM"

ELECTRICAL 电动:

VOLTAGE 电压:125 VOLTS AC
CURRENT RATING 额定电流:1.5AMP
DIELECTRIC STRENGTH 介电强度:1000 VAC RMS 50HZ OR 60HZ,1MIN
INSULATION RESISTANCE 绝缘电阻:500 MEGA OHMS MIN.INITIAL
AFTER 50V DC FOR 1 MINUTE
CONTACT RESISTANCE 接触电阻:SINGLE TERMINAL 30 MILLIOHMS MAX
INITIAL 50 MILLIOHMS MAX.AFTER
DURABILITY TEST

广东星坤科技股份有限公司

ΔX	日期
ΔX	日期
ΔX	日期
MARK	

文件工程章

REVISIONS	DESCRIPTION	DATE	REVISED	APPROVED	UNSPECIFIED TOLERANCES
					ANGULAR ±5°
					L ≤ 4 ±0.2
					4 < L ≤ 16 ±0.3
					16 < L ≤ 63 ±0.4
					L > 63 ±0.5

www.helloxkb.com www.helloxkb.cn www.xk-dg.cn



XKB INDUSTRIAL PRECISION CO., LIMITED

DSND	SCALE: N/A	MODEL TYPE: RJ JACK
DWN	VIEW:	PART NO.:
CHKD	UNIT: mm/in	DWG NO.: X10ADIWK1DY1006
APPD	SIZE: A4	WEIGHT SHEET REVISION
		1/1 A0