

Specifications:

规格:

Voltage rating:30V AC/DC

额定电压: 30V AC/DC

Current rating:3A AC/DC

额定电流: 3A AC/DC

Withstanding voltage:500V AC/minute

耐受电压: 500V AC/分钟

Temperature range:-40°C~+125°C

温度范围: -40°C~+125°C

Insulation resistance:100MΩ min

绝缘电阻: 100MΩ Min

Contact resistance:20mΩ Max

接触电阻: 20mΩ Max

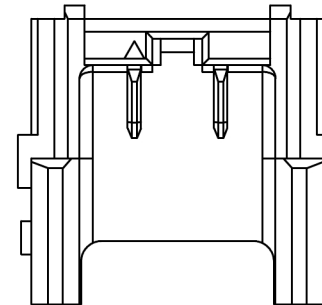
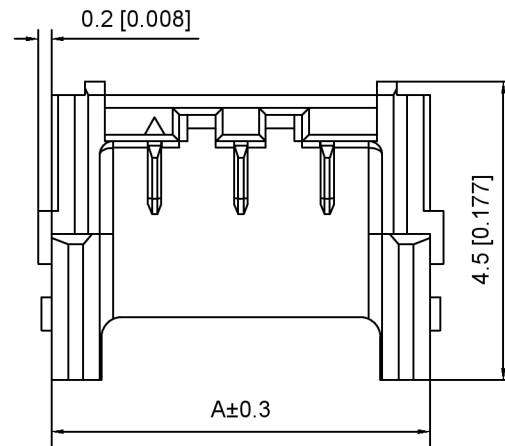
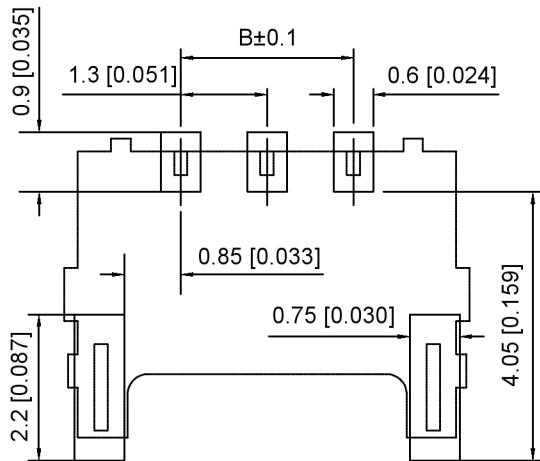

X1300 W R S - XX - 4T V01 X
 ① ② ③ ④ ⑤ ⑥ ⑦ ⑧

- 1.Series No
- 2.Category:W-Wafer
- 3.Welding Board Angle:R-Stright 90°
- 4.Welding Way:S-SMT
- 5.Row No.Pin No:XX-02~12 Pin
- 6.Material:4T-PA4T UL94V-0
- 7.Plating:V01:Gold Flash
- 8.Color:Blank-Natural ; BK-Black

Recommended PCB Layout
 General Tolerance:±0.05

3~12 Pin Shape

02 Pin Shape

Poles	Dimensions(mm)			Poles	Dimensions(mm)		
	A	B	C		A	B	C
02	4.40	1.30	3.70	08	12.20	9.10	11.50
03	5.70	2.60	5.00	09	13.50	10.40	12.80
04	7.00	3.90	6.30	10	14.80	11.70	14.10
05	8.30	5.20	7.60	11	16.10	13.00	15.40
06	9.60	6.50	8.90	12	17.40	14.30	16.70
07	10.90	7.80	10.20		/		

X1300WRS-XX-4TV01	Brass	Gold Flash	X1300H
X1300WRS-XX-4TV01BK			
PART NO	Material	Plating	Suitable XKB Housing

DSND	SCALE: N/A	MODEL TYPE: 1.3mm Crimp Style Connector
DWN	VIEW:	PART NO.: X1300WRS-XX-4TV01
CHKD	UNIT: mm/in	DWG NO.: X-X1300WRS-XX-4TV01
APPD	SIZE: A4	



XKB INDUSTRIAL PRECISION CO., LIMITED

WEIGHT	SHEET	REVISION
	1/1	A0

MARK	DESCRIPTION	DATE	REVISED	APPROVED	ANGLAR	±5°
ΔX					L ≤ 4	±0.2
ΔX					4 < L ≤ 16	±0.3
ΔX					16 < L ≤ 63	±0.4
MARK					L > 63	±0.5
REVISIONS					UNSPECIFIED TOLERANCES	
www.helloxkb.com www.helloxkb.cn www.xk-dg.cn						