

Specifications:  
 规格:  
 Voltage rating:250V AC/DC  
 额定电压: 250V AC/DC  
 Current rating:3A AC/DC  
 额定电流: 3A AC/DC  
 Withstanding voltage:500V AC/minute  
 耐受电压: 500V AC/分钟  
 Temperature range:-25°C~+85°C  
 温度范围: -25°C~+85°C  
 Insulation resistance:≥1000MΩ  
 绝缘电阻: ≥1000MΩ  
 Contact resistance:≤20mΩ  
 接触电阻: ≤20mΩ

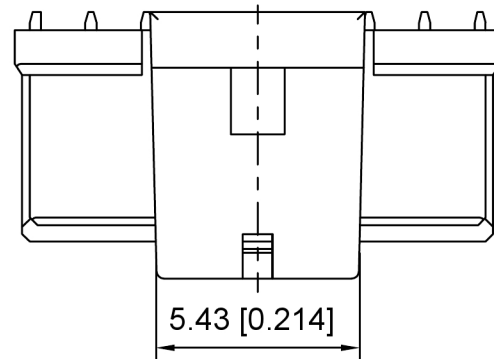

X1511 H - XX L - N0  
 ① ② ③ ④ ⑤

- 1.Series No
- 2.Category:H-HSG
- 3.Row No.Pin No:XX-02~10P
- 4.Special No:L-With Lock
- 5.Material:N0- PA66 UL94V-0 ;

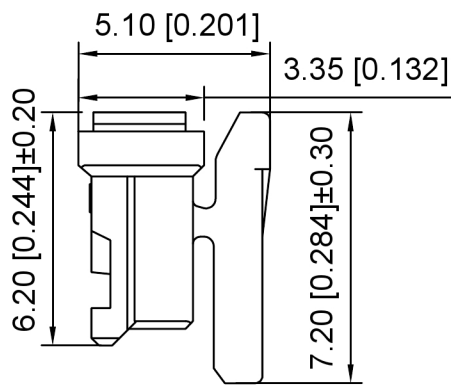
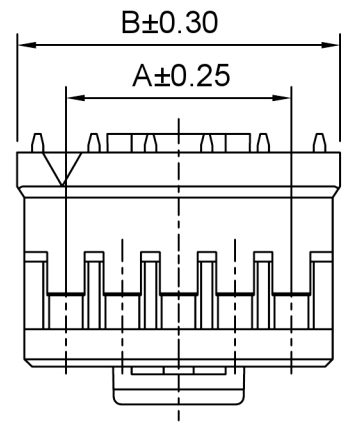
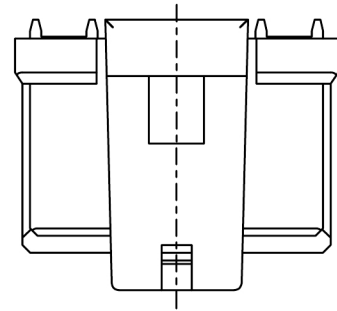
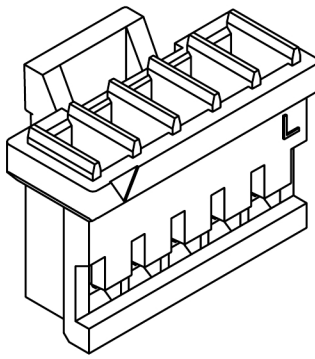
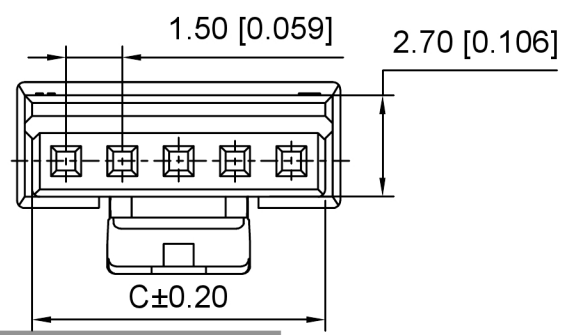

Poles	Dimensions(mm)			Poles	Dimensions(mm)		
	A	B	C		A	B	C
02	1.50	4.10	3.30	09	12.00	14.60	13.80
03	3.00	5.60	4.80	10	13.5	16.10	15.30
04	4.50	7.10	6.30	11	15.00	17.60	16.80
05	6.00	8.60	7.80	12	16.5	19.10	18.30
06	7.50	10.10	9.30	13	18.00	20.60	19.80
07	9.00	11.60	10.80	14	19.50	22.10	21.30
08	10.50	13.10	12.30	15	21.00	23.60	22.80

X1511H-XXL-N0	PA66	X1511W-L	X1511T-L
PART NO	Material	Suitable XKB Wafer	Suitable XKB Terminal

广东星坤科技股份有限公司

Δx	日期
Δx	日期
Δx	日期
MARK	DESCRIPTION

文件工程章

REVISIONS	DATE	REVISED	APPROVED	UNSPECIFIED TOLERANCES
ANGLAR				±5°
L ≤ 4				±0.2
4 < L ≤ 16				±0.3
16 < L ≤ 63				±0.4
L > 63				±0.5



DSND	SCALE: N/A	MODEL TYPE: 1.5mm Crimp Style Connector
DWN	VIEW:	PART NO.: X1511H-XXL-N0
CHKD	UNIT: mm/in	DWG NO.: X-X1511H-XXL-N0
APPD	SIZE: A4	WEIGHT

XKB INDUSTRIAL PRECISION CO., LIMITED

SHEET	REVISIC
1/1	A0