

**Specifications:**

规格:

Voltage rating:100V AC/DC

额定电压: 100V AC/DC

Current rating:1.5A AC/DC

额定电流: 1.5A AC/DC

Withstanding voltage:500V AC/minute

耐受电压: 500V AC/分钟

Temperature range:-40℃-+105℃

温度范围: -40℃-+105℃

Insulation resistance:≥500MΩ

绝缘电阻: ≥500MΩ

Contact resistance:≤20mΩ

接触电阻: ≤20mΩ

**X1515 W V S-2xXX - LP SW**

① ② ③ ④ ⑤ ⑥ ⑦

1.Series No

2.Category:W-Wafer

3.Welding Board Angle:V-Stright 180°

4.Welding Way:S-SMT

5.Row No.Pin No:2xXX-2x04~2x14P

6.Material:LP-LCP UL94V-0 (Natural)

7.Plating:SW- Matte Tin Plated

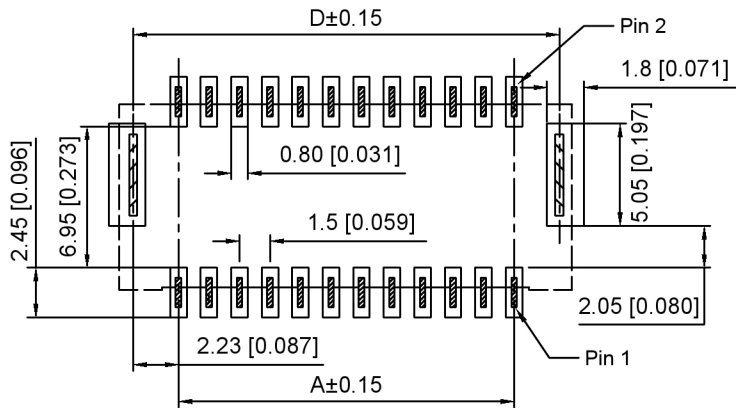

**Recommended PCB Layout**  
Tolerance:±0.05

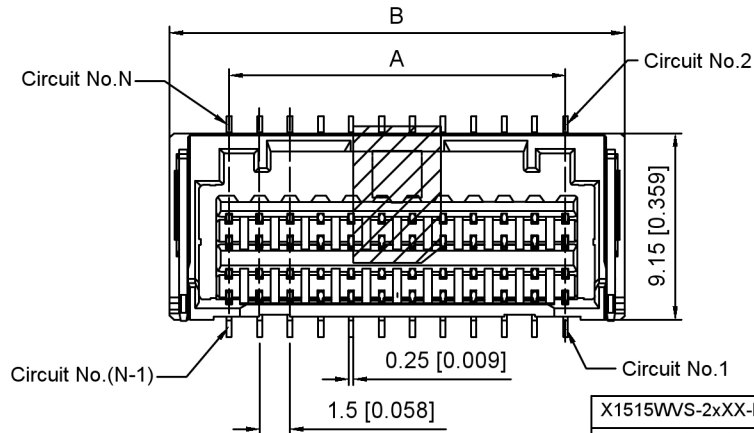

Poles	Dimensions(mm)			
	A	B	C	D
2x04	4.50	10.30	8.50	8.95
2x05	6.00	11.80	10.00	10.45
2x06	7.50	13.30	11.50	11.95
2x07	9.00	14.80	13.00	13.45
2x08	10.50	16.30	14.50	14.95
2x09	12.00	17.80	16.00	16.45
2x10	13.50	19.30	17.50	17.95
2x11	15.00	20.80	19.00	19.45
2x12	16.50	22.30	20.50	20.95
2x13	18.00	23.80	22.00	22.45
2x14	19.50	25.30	23.50	23.95

X1515WVS-2xXX-LPSW	LCP	Phosphor Bronze	X1515H-A
PART NO	Material	Material(Pin)	Suitable XKB Housing

DSND	SCALE: N/A	MODEL TYPE: 1.5mm Crimp Style Connector
DWN	VIEW:	PART NO.: X1515WVS-2xXX-LPSW
CHKD	UNIT: mm/in	DWG NO.: X-X1515WVS-2xXX-LPSW
APPD	SIZE: A4	WEIGHT SHEET REVISION 1/1 A0



XKB INDUSTRIAL PRECISION CO., LIMITED

ANGULAR	±5°
L ≤ 4	±0.2
4 < L ≤ 16	±0.3
16 < L ≤ 63	±0.4
L > 63	±0.5
UNSPECIFIED TOLERANCES	

广东星坤科技股份有限公司

Δx	日期
Δx	
Δx	
校核	

文件工程章

REVISIONS	DATE	REVISED	APPROVED

www.helloxkb.com www.helloxkb.cn www.xk-dg.cn