

REVISIONS					
REV.	ECN NO.	LOCATION	DESCRIPTION	DATE	DESIGN
A0	N/A		INITIAL RELEASE	2024.02.29	

Specifications (规格):

1. Voltage rating (额定电压): 250V AC DC
2. Current rating (额定电流): 3.0A AC/DC
3. Withstanding voltage (耐压值): $\geq 1000V$ AC/minute
4. Insulation resistance (绝缘电阻): $1000M\Omega$ Min
5. Contact resistance (接触电阻): $20m\Omega$ Max
6. Temperature range (使用温度): $-25^{\circ}C \sim +105^{\circ}C$

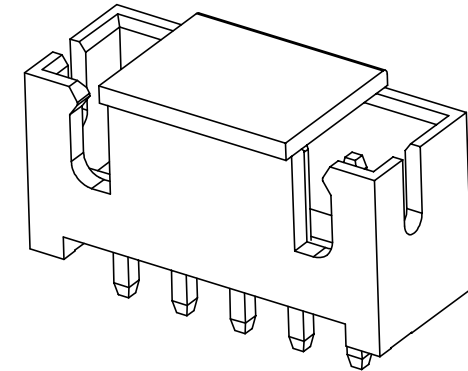

3D VIEW

PART NO.:

X8821 W V-XX S R-LP SN
 ① ② ③ ④ ⑤ ⑥ ⑦ ⑧

- ① Series No
- ② Category: W-Wafer
- ③ Welding Board Angle: V-Straight 180°
- ④ Row No-Pin: XX-02P~16P
- ⑤ Special No: S-No Positioning
- ⑥ Special No: R-DIP 2.2mm
- ⑦ Material: LP-LCP UL94V-0
- ⑧ Plating: SN-Tin Plated

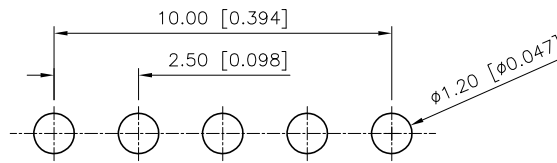
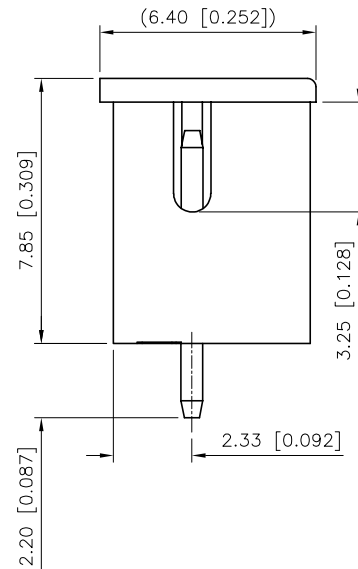
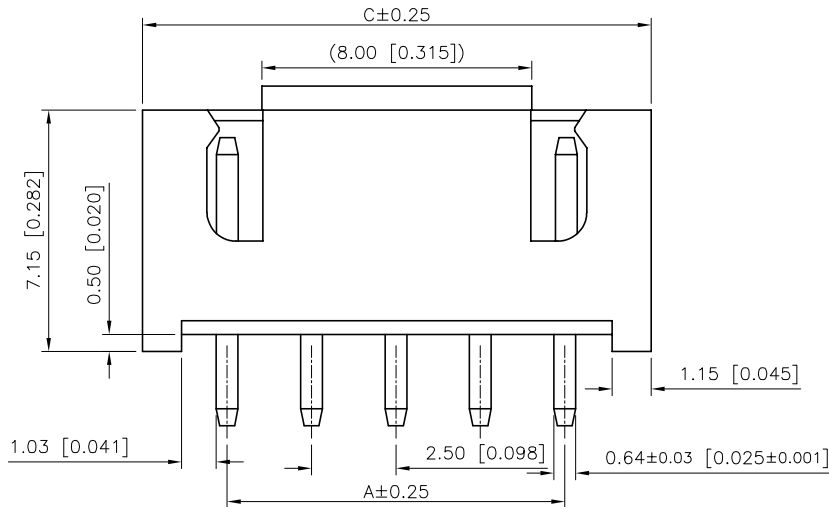
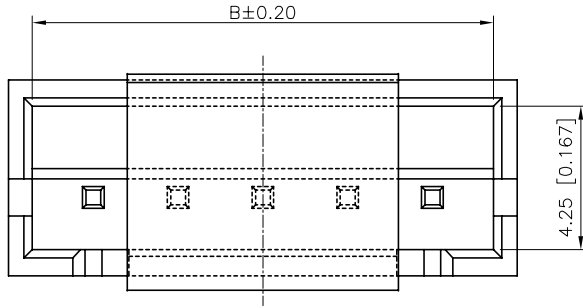

PCB LAYOUT

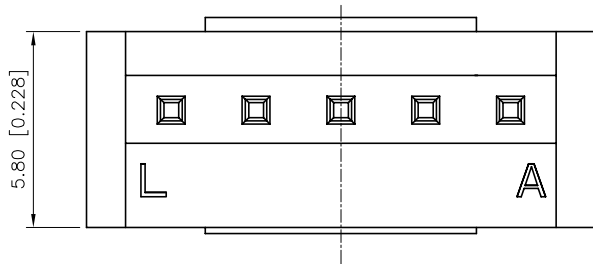

NUMBER OF POSITIONS	DIM.A	DIM.B	DIM.C	NUMBER OF POSITIONS	DIM.A	DIM.B	DIM.C
02	2.50	6.10	7.50	10	22.50	26.10	27.50
03	5.00	8.60	10.00	11	25.00	28.60	30.00
04	7.50	11.10	12.50	12	27.50	31.10	32.50
05	10.00	13.60	15.00	13	30.00	33.60	35.00
06	12.50	16.10	17.50	14	32.50	36.10	37.50
07	15.00	18.60	20.00	15	35.00	38.60	40.00
08	17.50	21.10	22.50	16	37.50	41.10	42.50
09	20.00	23.60	25.00				

X8821WV-XXSR-LPSN	LCP UL 94V-0	BRASS	Sn-PLATED	X8821H
PART NO.	MATERIAL	MATERIAL(PIN)	FINISH(PIN)	Suitable XKB Terminal

ANGLAR	±5°
X.	±0.40
X.x	±0.30
X.xx	±0.20
X.xxx	±0.15
UNSPECIFIED TOLERANCES	



DESIGN	桑葚	VIEW:		MODEL TYPE:	2.50mm Crimp Style Connector
CHECKED		UNIT:	mm/in	PART NO.:	X8821WV-XXSR-LPSN
APPROVED		SIZE:	A4	DWG NO.:	

XKB INDUSTRIAL PRECISION CO.,LIMITED

SCALE	PAGE	REVISION
N/A	1/1	A0