

Specifications:
 规格:
 Voltage rating:600V AC/DC
 额定电压: 600V AC/DC
 Current rating:7A AC/DC
 额定电流: 7A AC/DC
 Withstanding voltage:1500V AC/minute
 耐受电压: 1500V AC/分钟
 Temperature range:-25°C~+85°C
 温度范围: -25°C~+85°C
 Insulation resistance:1000MΩ min
 绝缘电阻: 1000MΩ Min
 Contact resistance:20mΩ Max
 接触电阻: 20mΩ Max

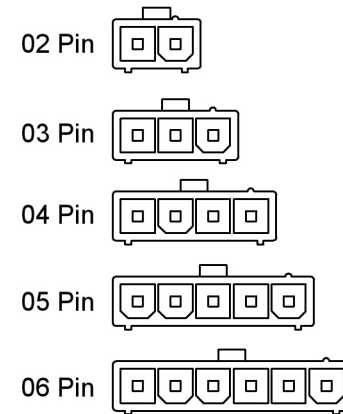
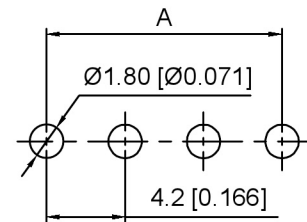
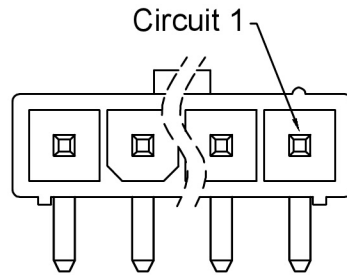
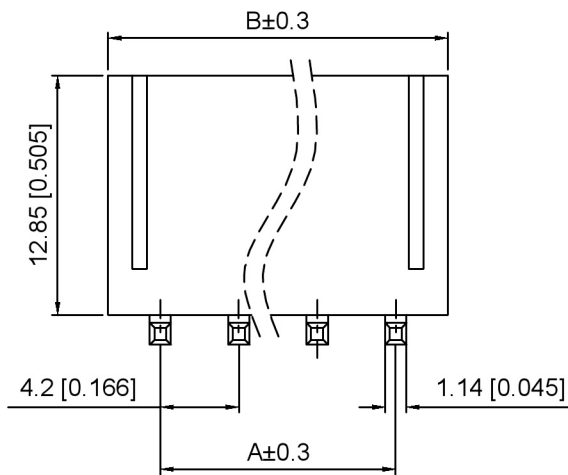

X9357 W R - XX - N2 SN
 ① ② ③ ④ ⑤ ⑥

- Series No
- Category:W-Wafer
- Welding Board Angle:R-Stright 90°
- Row No.Pin No:XX-02~06P
- Material:N0-PA66 UL94V-0 ; N2-PA66 UL94V-2
- Plating:SN-Tin Plated

Poles	Dimensions(mm)	
	A	B
02	4.20	9.80
03	8.40	14.00
04	12.60	18.20
05	16.80	22.40
06	21.00	26.60

Circuit size Layout

X9357WR-XX-N2SN	PA66	Brass	X9357HM
PART NO	Material	Material(Pin)	Suitable XKB Housing

广东星坤科技股份有限公司

文件工程章

MARK	DESCRIPTION	DATE	REVISED	APPROVED	UNSPECIFIED TOLERANCES
Δ#					ANGLAR ±5°
ΔX					L ≤ 4 ±0.2
Δ效					4 < L ≤ 16 ±0.3
					16 < L ≤ 63 ±0.4
					L > 63 ±0.5



XKB INDUSTRIAL PRECISION CO., LIMITED

DSND	SCALE: N/A	MODEL TYPE: 4.2mm Crimp Style Connector
DWN	VIEW:	PART NO.: X9357WR-XX-N2SN
CHKD	UNIT: mm/in	DWG NO.: X-X9357WR-XX-N2SN
APPD	SIZE: A4	WEIGHT SHEET REVISION 1/1 A0