

04P~30P

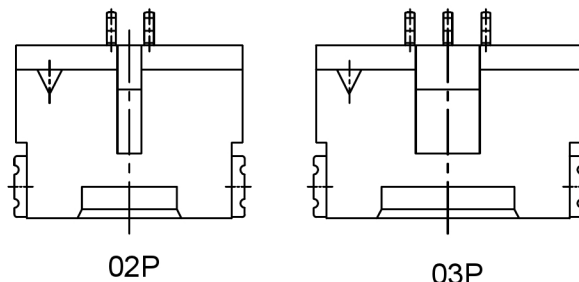
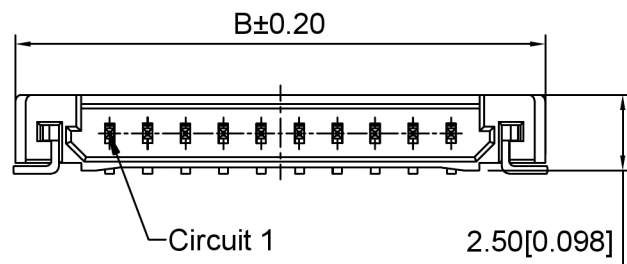

Specifications:
 规格:
Voltage rating:150V AC/DC
 额定电压: 150V AC/DC
Current rating:1A AC/DC
 额定电流: 1A AC/DC
Withstanding voltage:500V AC/minute
 耐受电压: 500V AC/分钟
Temperature range:-25℃~+85℃
 温度范围: -25℃~+85℃
Insulation resistance : 500MΩ min
 绝缘电阻: 500MΩ Min
Contact resistance:30mΩ Max
 接触电阻: 30mΩ Max

X9862 W R S -XX -6T SN
 ① ② ③ ④ ⑤ ⑥ ⑦

- 1.Series No
- 2.Category:W-Wafer
- 3.Welding Board Angle:R-Straight 90°
- 4.Welding Way:S-SMT
- 5.Row No.Pin No:XX-02P-30P
- 6.Material:6T-PA6T UL94V-0 Beige
- 7.Plating:SN-Bright Tin Plating

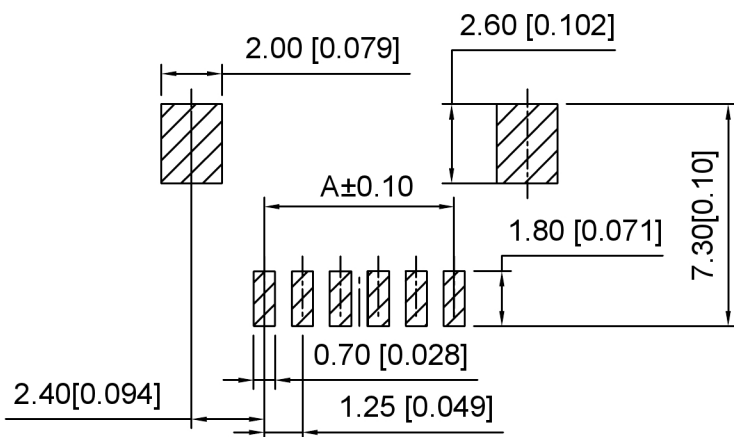

P.C.B LAYOUT

Poles	DIM.(mm)	
	A	B
02	1.25	7.45
03	2.50	8.70
04	3.75	9.95
05	5.00	11.20
06	6.25	12.45
07	7.50	13.70
08	8.75	14.95
09	10.00	16.20
10	11.25	17.45
11	12.50	18.70
12	13.74	19.95
13	15.00	21.20
14	16.25	22.45
15	17.50	23.70
20	23.75	29.95
25	30.00	36.20
30	36.25	42.45

X9862WRS-XX-6TSN	PA6T	Brass	X9862H
PART NO	Material	Material(Pin)	SUITable XKI Housing

DSND	SCALE: N/A	MODEL TYPE: 1.25mm Crimp Style Connector
DWN	VIEW:	PART NO.: X9862WRS-XX-6TSN
CHKD	UNIT: mm/in	DWG NO.: X-X9862WRS-XX-6TSN
APPD	SIZE: A4	WEIGHT SHEET REVISIC 1/1 A0

广东星坤科技股份有限公司

ΔX	日期
ΔX	日期
ΔX	日期
MARK	DESCRIPTION

文件工程章

REVISIONS	DATE	REVISED	APPROVED	UNSPECIFIED TOLERANCES
ANGLAR				±5°
L ≤ 4				±0.2
4 < L ≤ 16				±0.3
16 < L ≤ 63				±0.4
L > 63				±0.5



XKB INDUSTRIAL PRECISION CO., LIMITED

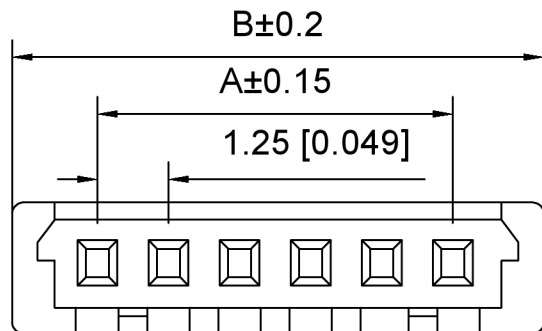
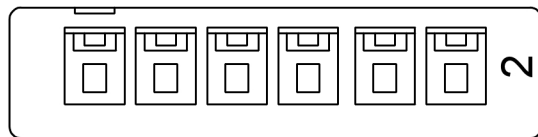

03P~30P

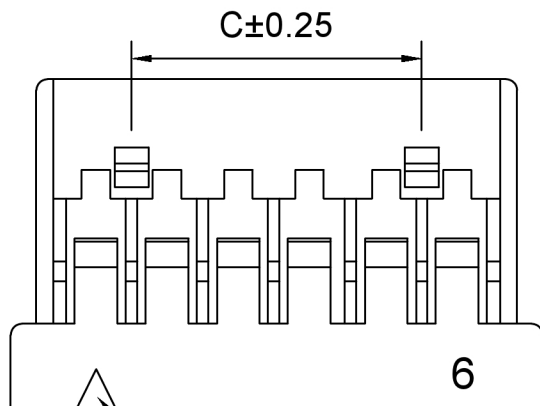

Circuit 1

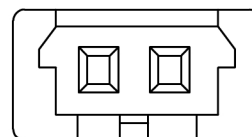
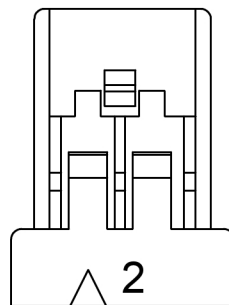

02P

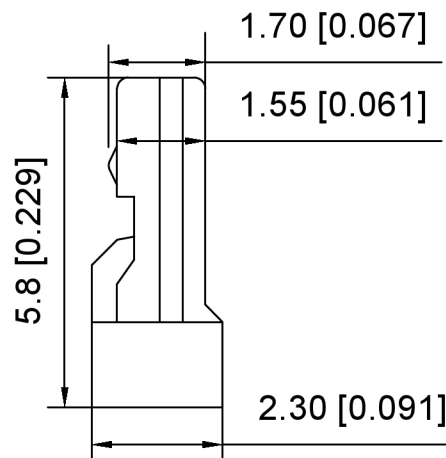

Specifications:

规格:

Voltage rating:150V AC/DC

额定电压: 150V AC/DC

Current rating:1A AC/DC

额定电流: 1A AC/DC

Withstanding voltage:500V AC/minute

耐受电压: 500V AC/分钟

Temperature range:-25°C~+85°C

温度范围: -25°C~+85°C

Insulation resistance:500MΩ min

绝缘电阻: 500MΩ Min

Contact resistance:30mΩ Max

接触电阻: 30mΩ Max

X9862 H -XX - N0



1.Series No

2.Category:H-HSG

3.Row No.Pin No:XX-02P-30P

4.Material:N0-Nylon66

UL 94V-0 Grey

Poles	DIM		
	A	B	C
02	1.25	4.35	/
03	2.50	5.60	1.25
04	3.75	6.85	2.50
05	5.00	8.10	3.75
06	6.25	9.35	5.00
07	7.50	10.60	6.25
08	8.75	11.85	7.50
09	10.00	13.10	8.75
10	11.25	14.35	10.00
11	12.50	15.60	11.25
12	13.75	16.85	12.50
13	15.00	18.10	13.75
14	16.25	19.35	15.00
15	17.50	20.60	16.25
20	23.75	26.85	22.50
25	30.00	33.10	28.75
30	36.25	39.35	35.00

X9862H-XX-N0	Nylon 66	X9862W	X9862T
PART NO	Material	Suitable XKB Wafer	Suitable XKB Terminal

DSND	SCALE: N/A	MODEL TYPE: 1.25mm Crimp Style Connector
DWN	VIEW:	PART NO.: X9862H-XX-N0
CHKD	UNIT: mm/in	DWG NO.: X-X9862H-XX-N0
APPD	SIZE: A4	



XKB INDUSTRIAL PRECISION CO.,LIMITED

WEIGHT	SHEET	REVISION
	1/1	A0

广东星坤科技股份有限公司

Δx	日期
Δx	日期
Δx	日期
MARK	DESCRIPTION

文件工程章

REVISIONS	DATE	REVISED	APPROVED	UNSPECIFIED TOLERANCES
ANGLAR				±5°
L ≤ 4				±0.2
4 < L ≤ 16				±0.3
16 < L ≤ 63				±0.4
L > 63				±0.5

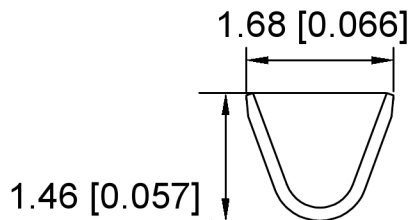
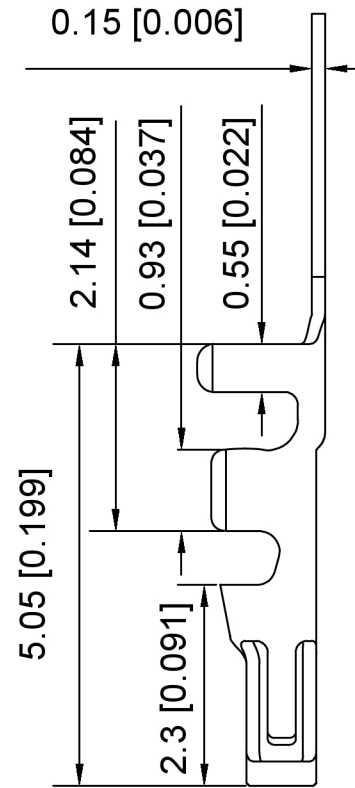
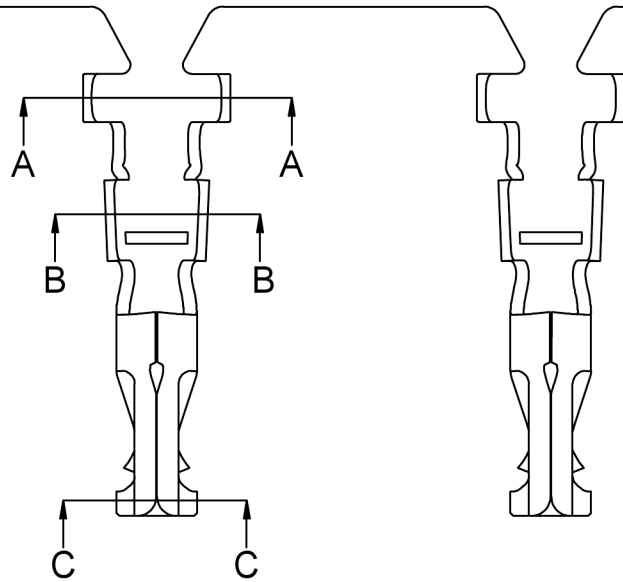
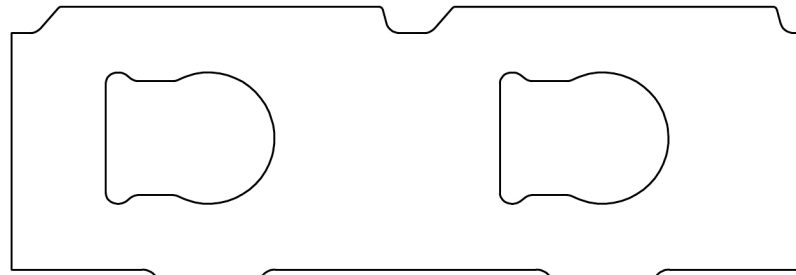

Section A-A

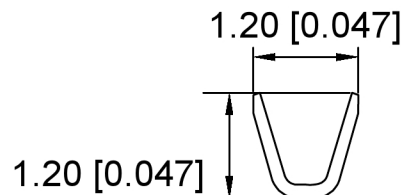

Section B-B

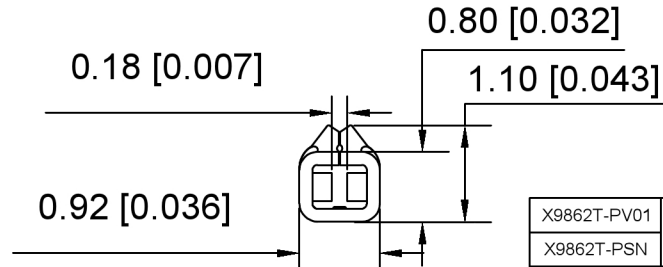

Section C-C

Specifications:

规格:

Voltage rating: 150V AC/DC

额定电压: 150V AC/DC

Current rating: 1A AC/DC

额定电流: 1A AC/DC

Withstanding voltage: 500V AC/minute

耐受电压: 500V AC/分钟

Temperature range: -25°C +85°C

温度范围: -25°C +85°C

Insulation resistance: 500MΩ min

绝缘电阻: 500MΩ Min

Contact resistance: 30mΩ Max

接触电阻: 30mΩ Max

X9862 T - P V01

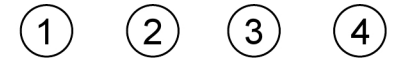

1. Series No

2. Category: T-Terminal

3. Material: P-Phosphor Bronze

4. Plating: V01-Gold Flash
SN-Tin Plated

X9862T-PV01	PHOSPHOR BRONZE	AWG#28-32 O.D.0.9mm (Max)	Gold Flash	X9862H
X9862T-PSN			Tin	
PART NO	Material	Wire Range	Plating	Suitable XKB Housing

DSND	SCALE: N/A	MODEL TYPE: 1.25mm Crimp Style Connector
DWN	VIEW:	PART NO.: X9862T-PV01
CHKD	UNIT: mm/in	DWG NO.: X9862T-PV01
APPD	SIZE: A4	WEIGHT
XKB INDUSTRIAL PRECISION CO., LIMITED		SHEET
		REVISION
		1/1
		A0

广东星坤科技股份有限公司

ANGLAR	±5°
L ≤ 4	±0.2
4 < L ≤ 16	±0.3
16 < L ≤ 63	±0.4
L > 63	±0.5
UNSPECIFIED TOLERANCES	



文件工程章

REVISIONS
www.helloxkb.com www.helloxkb.cn www.xk-dg.cn