



## General Description

SY6282 is ultra-low  $R_{DS(ON)}$  switch with programmable current limit to protect the power source from over current and short circuit conditions. It incorporates over temperature protection and reverse blocking function.

## Ordering Information

SY6282 □(□)□□  
└───┬───┬───┬───┘  
      └───┘ Temperature Code  
      └───┘ Package Code  
      └───┘ Optional Spec Code

Ordering Number	Package type	Note
SY6282ACC	TSOT23-5	

## Features

- Input Voltage: 2.4V to 6V
- 3A Load Current Capability
- Programmable Current Limit
- Over Temperature Protection
- Reverse Blocking (No Body Diode)
- OUT Can be Forced Higher Than IN at Shutdown
- Compact TSOT23-5 Package Minimizes the Board Space
- RoHS Compliant and Halogen Free

## Applications

- USB 3G Datacard
- USB Dongle
- MiniPCI Accessories
- USB Charger
- Public Place Multi-USB Charger

## Typical Application

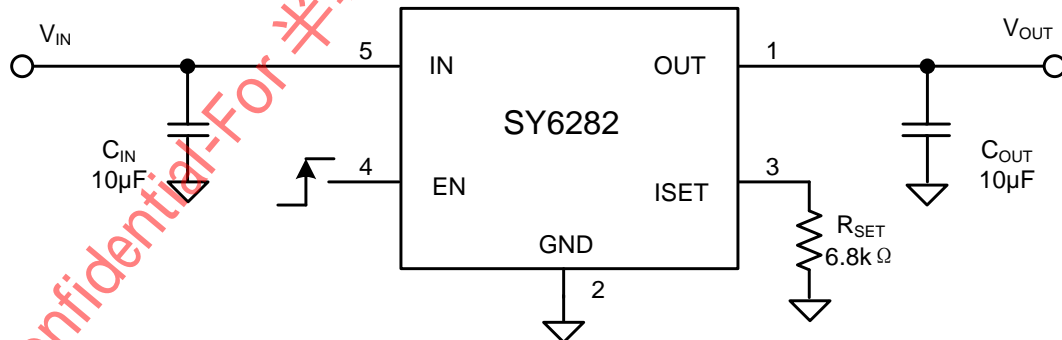
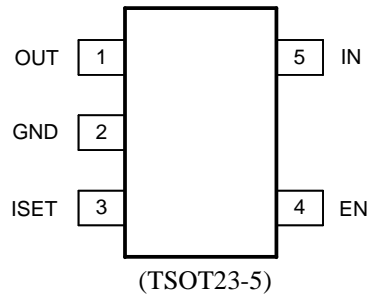

Figure1. Schematic Diagram

## Pinout (top view)



Top mark: **Lnxzy** for SY6282ACC (Device code: Ln, x=year code, y=week code, z=lot number code)

Pin Name	Pin number	Pin Description
OUT	1	Output pin, decoupled with a 10µF capacitor to GND.
GND	2	Ground pin.
ISET	3	Current limit programming pin. Connect a resistor R <sub>SET</sub> from this pin to ground to program the current limit: I <sub>LIM</sub> (A)=6800/R <sub>SET</sub> (Ω)
EN	4	ON/OFF control. Pull high to enable IC. Do not leave it floating.
IN	5	Input pin, decoupled with a 10µF capacitor to GND.

## Block Diagram

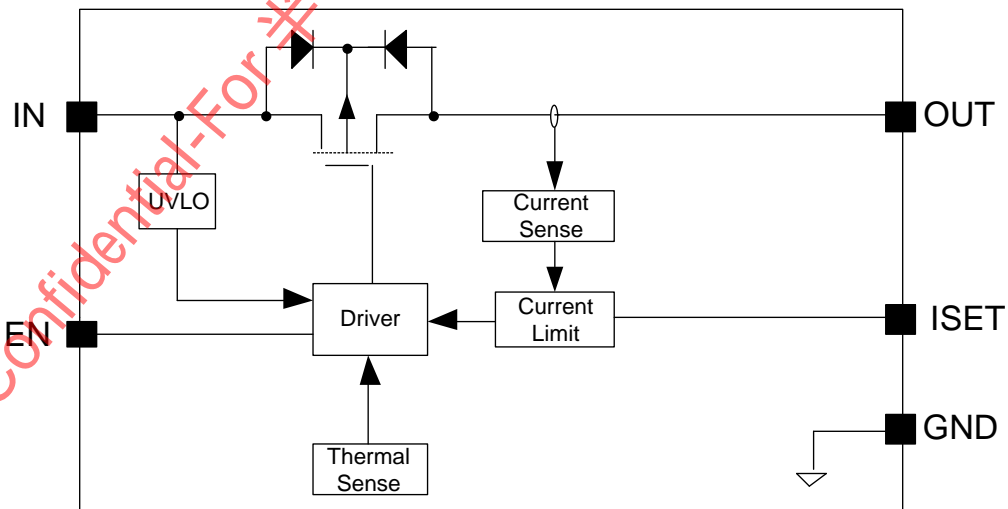

Figure2. Block Diagram



## Absolute Maximum Ratings (Note 1)

IN, OUT, EN, ISET	-0.3V to 7V
Power Dissipation, $P_D$ @ $T_A = 25^\circ\text{C}$ TSOT23-5	1.46W
Package Thermal Resistance (Note 2)	
$\theta_{JA}$	68.5°C/W
$\theta_{JC}$	10.9°C/W
Junction Temperature Range	-40°C to 150°C
Lead Temperature (Soldering, 10 sec.)	260°C
Storage Temperature Range	-65°C to 150°C

## Recommended Operating Conditions (Note 3)

IN	2.4V to 6V
OUT, ISET	0V to 6V
EN	0V to IN
Junction Temperature Range	-40°C to 125°C
Ambient Temperature Range	-40°C to 85°C

## Electrical Characteristics

( $V_{IN} = 5V$ ,  $C_{OUT} = 10\mu\text{F}$ ,  $T_A = 25^\circ\text{C}$ , unless otherwise specified.)

Parameter	Symbol	Test Conditions	Min	Typ	Max	Unit
Input Voltage Range	$V_{IN}$		2.4		6	V
Shutdown Input Current	$I_{SHDN}$	Open load, IC disabled		0.2	1	$\mu\text{A}$
Quiescent Supply Current	$I_Q$	Open load, IC enabled		38		$\mu\text{A}$
FET $R_{ON}$	$R_{DS(ON)}$			50		m $\Omega$
EN Rising Threshold	$V_{EN(H)}$		2			V
EN Falling Threshold	$V_{EN(L)}$				0.8	V
EN Leakage Current	$I_{EN}$	$V_{EN} = 5.0V$			1	$\mu\text{A}$
IN UVLO Threshold	$V_{IN\_UVLO}$				2.3	V
IN UVLO Hysteresis	$V_{IN\_HYS}$			0.1		V
Over Current Limit	$I_{LIM}$	$R_{SET} = 6.8k\Omega$	0.75	1	1.25	A
Programmable Current Limit Range	$I_{RANGE}$		0.4		3.5	A
Turn-on Time	$t_{ON}$	$R_L = 10\Omega$ , $C_{OUT} = 1\mu\text{F}$		130		$\mu\text{s}$
Turn-off Time	$t_{OFF}$	$R_L = 10\Omega$ , $C_{OUT} = 1\mu\text{F}$		20		$\mu\text{s}$
Thermal Shutdown Temperature	$T_{SD}$			150		$^\circ\text{C}$
Thermal Shutdown Hysteresis	$T_{SD\_HYS}$			20		$^\circ\text{C}$

**Note 1:** Stresses beyond the “Absolute Maximum Ratings” may cause permanent damage to the device. These are stress ratings only. Functional operation of the device at these or any other conditions beyond those indicated in the operational sections of the specification is not implied. Exposure to absolute maximum rating conditions for extended periods may affect device reliability.

**Note 2:**  $\theta_{JA}$  is measured in the natural convection at  $T_A = 25^\circ\text{C}$  on a Silergy test board. Pin 2 of TSOT23-5 package is the case position for  $\theta_{JC}$  measurement.

**Note 3:** The device is not guaranteed to function outside its operating conditions.

**TSOT23-5 Package outline & PCB Layout Design**

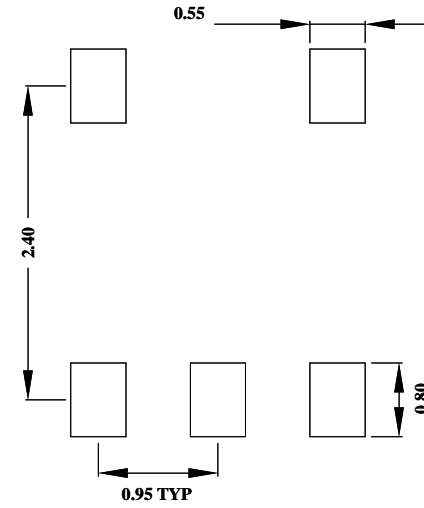

**Recommended Pad Layout**

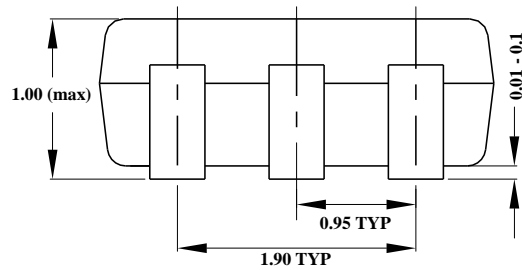
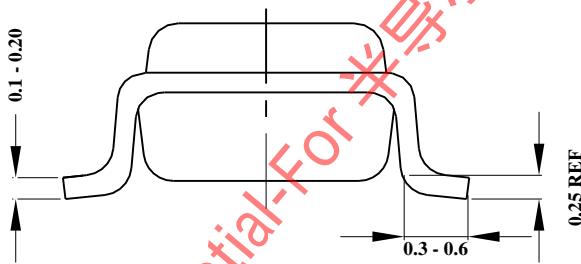
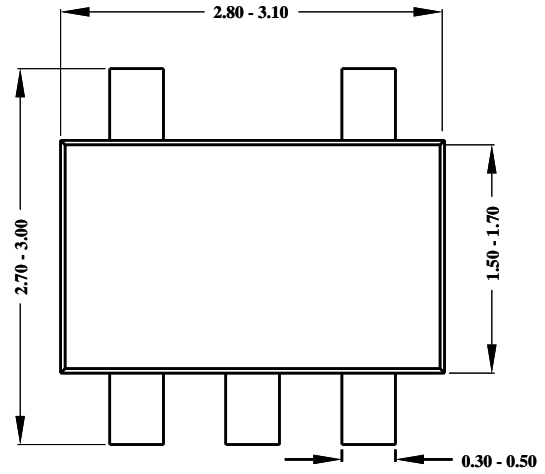

**Notes:** All dimensions are in millimeters.  
All dimensions don't include mold flash & metal burr.

## Taping & Reel Specification

### 1. Taping orientation

TSOT23-5

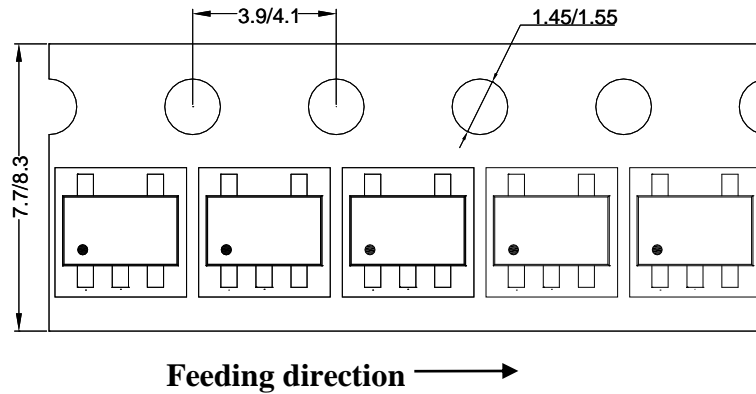

### 2. Carrier Tape & Reel specification for packages

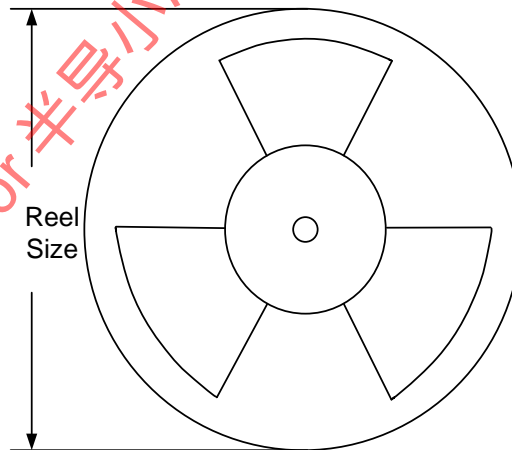

Package types	Tape width (mm)	Pocket pitch(mm)	Reel size (Inch)	Reel width(mm)	Trailer length(mm)	Leader length (mm)	Qty per reel
TSOT23-5	8	4	7"	8.4	280	160	3000

### 3. Others: NA