



中山市中立电子有限公司
中山市发音电子制造有限公司

样品承认书

Specifications



已通过ISO9001:2008质量管理体系认证

2018

产品名称 Rariety	压电式无源蜂鸣器
客户名称/代码 Customer Name	10371
客户型号/代码 Cu Ppart No	
中立型号 ZL Ppart No	ZL-YDW13025-4005W30
样品日期 Model Date	2018-05-02

客户承认签署

签定结果:

核准/Approved	审核/Checked	经办/Designed

中立确认签署

核准/Approved	审核/Checked	经办/Designed

承认后请签回一份! Thank you very much





中山市中立电子有限公司 中山市发音电子制造有限公司

样品承认书

型号 Ppart No: ZL-YDW13025-4005W30		
1	额定频率 Resonance Frequency (KHz)	4.0
2	最大电压 Max Input Voltage (Vp-p)	30
3	电容量 Capacitance at 120Hz (nF)	14±40%
4	*声压级 Sound Output at 10cm (dB)	≥70 at 4.0KHz Square Wave 5Vp-p
5	*消耗电流 Current Consumption (mA)	≤5 at 4.0KHz Square Wave 5Vp-p
6	工作温度 Operating Temperature (°C)	-20~+60
7	储存温度 Storage Temperature (°C)	-30~+70
8	单品重量 Weight (g)	0.4
9	外壳材料 Housing Material	Black ABS
带*号指标需要在额定电压下测试 *Applying rated voltage		

蜂鸣器焊接方法 Buzzer Soldering process	Soldering Parameter		
	温度 Temp.(°C)	时间 Time(Sec.)	可焊接次数 Times
回流焊 Reflow soldering	245±15	180°C 预热 40~70 秒 245°C 3 秒 above 180°C time 40~70	3
波峰焊 Wave soldering	255±5	4~6	2~3
★手工焊 Manual soldering	350±10	2~5	2~3
带★号为中立电子推荐的焊接方法 Remark:★ ZLFY Instance Soldering Process			

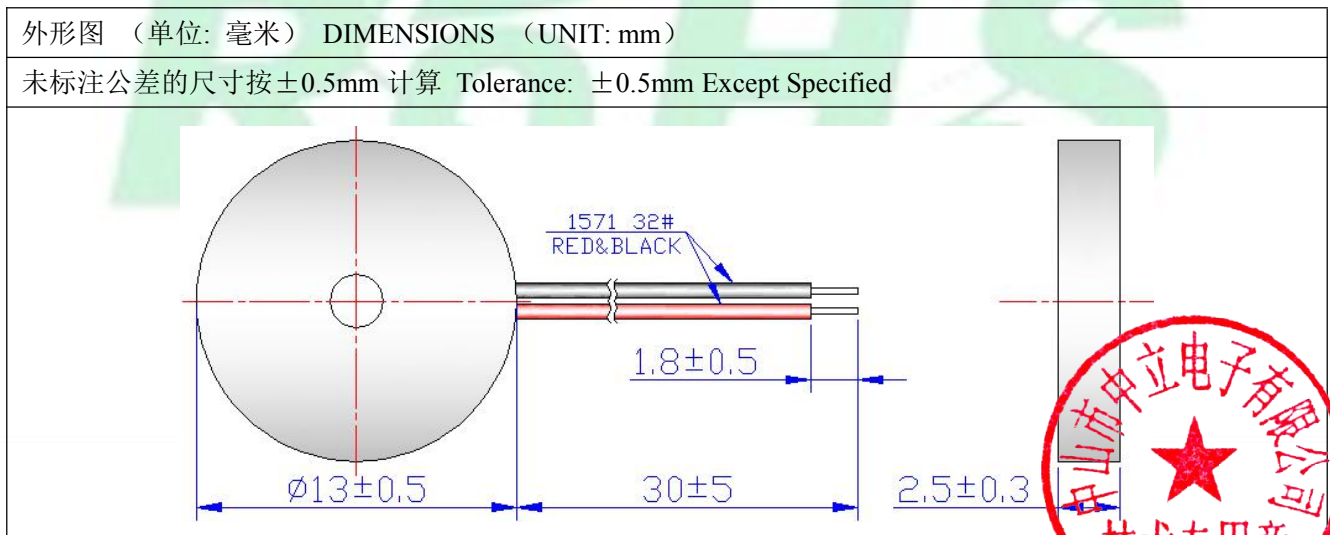



中山市中立电子有限公司
中山市发音电子制造有限公司
样品承认书

型号 Ppart No: ZL-YDW13025-4005W30

测试方法 TEST METHOD

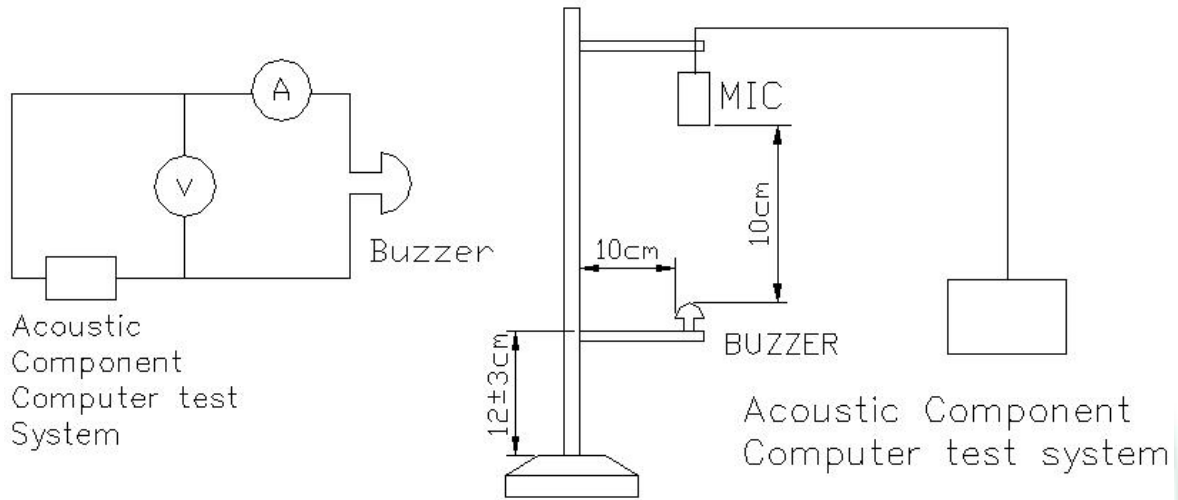

频响曲线 FREQUENCY RESPONSE

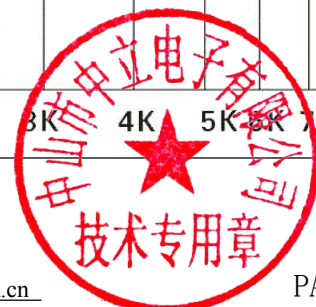
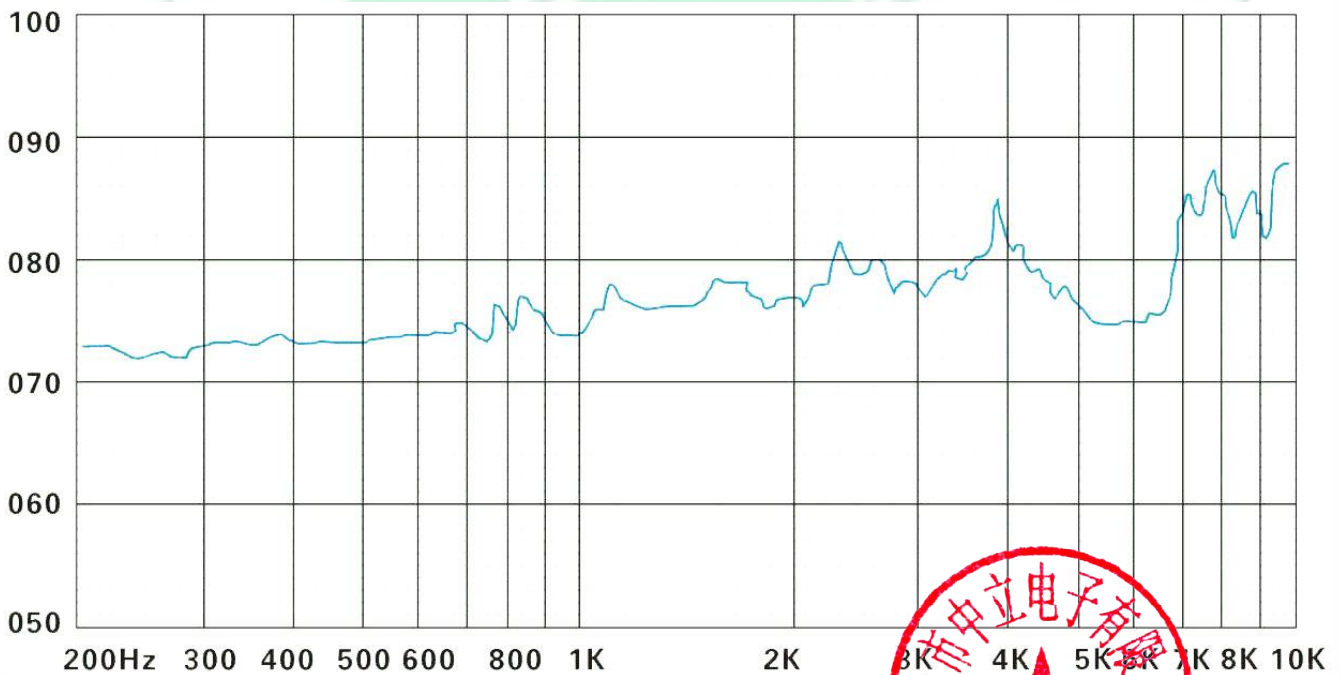



中山市中立电子有限公司
中山市发音电子制造有限公司
样品承认书

型号 Ppart No: ZL-YDW13025-4005W30			
可靠性测试 RELIABLY TEST			
NO	项目 ITEM	测试条件 TESTING CONDITION	试验后要求 VARIANCE AFTER TEST
1	湿热 Humidity	蜂鸣器置于温度在 $50 \pm 5^\circ\text{C}$ ，相对湿度在 $93\% - 3\% \sim 93\% + 2\%$ 中，保持 96 小时后，试验后在常温下恢复 2 小时测试	测试后性能指标应满足承认书要求 All specifications must be satisfied after the test.
		$50 \pm 5^\circ\text{C}$, 93(+2/-3)%RH, 96HRS	
2	高温测试 High temp.	蜂鸣器放置在 $+70 \pm 2^\circ\text{C}$ 中，96 小时后测试性能指标	
		$+70 \pm 2^\circ\text{C}$, 96HRS	
3	低温测试 Low temp.	将蜂鸣器放置在 $-30 \pm 2^\circ\text{C}$ 中，96 小时后测试性能指标	
		$-30 \pm 2^\circ\text{C}$, 96HRS	
4	温度循环测试 Temperature Cycling	蜂鸣器在 -30°C 暴露 30min，在 70°C 暴露 30min，五次循环后，试验后在常温下恢复 2 小时	
		$-30 \pm 2^\circ\text{C}$, 30minutes room temp. 15 minutes $+70 \pm 2^\circ\text{C}$, 30 minutes room temp. 15 minutes 5 cycles	
5	跌落 Drop test	将蜂鸣器放置在水平位置，从 700mm 高度自由跌落到 10mm 硬木版上，跌落 3 次后，检查外观并测量电性能 3 times from height of 70cm onto the surface of 10mm thick wooden board.	
6	振动 Vibration test	将蜂鸣器置于 10~55Hz、振幅在 1.0mm、X Y Z 轴线方向上振动 0.5 小时	
		Make the test for the directions of X Y and Z (total 0.5 hours). To-and-fro. sweep time (from 10 to 55 Hz and then from 55 to 10Hz) under single amplitude of 1.0mm is 1 minute.	
7	焊锡耐热性 Solder heat resistance	将产品针脚放置在 $250 \pm 10^\circ\text{C}$ 的锡炉里，持续 30 秒	
		The part leads (pins) shall be immersed in molten solder maintained at $250 \pm 10^\circ\text{C}$ for a period of 30 seconds.	





中山市中立电子有限公司
 中山市发音电子制造有限公司
 样品测试报告

No.S20180502003

产品型号		数量			测试数据			
ZL-YDW13025-4005W30		5 PCS			5 PCS			
测试条件	5VP-P, 4000Hz 方波信号, 在 10cm 处测试							
技术要求	声压级 $\geq 70\text{dB}$ 电流 $\leq 5\text{mA}$ 电容: $14 \pm 40\% \text{nF}$							
检测项目	声压 (dB)	电 流 (mA)	电 容 (nF)	检测项目	声压 (dB)	电 流 (mA)	电 容 (nF)	
录 记	1	80	0.61	14.8	录 记	26		
	2	81	0.60	14.4		27		
	3	80	0.62	14.5		28		
	4	80	0.60	13.8		29		
	5	81	0.60	14.9		30		
	6					31		
	7					32		
	8					33		
	9					34		
	10					35		
	11					36		
	12					37		
	13					38		
	14					39		
	15					40		
	16					41		
	17					42		
	18					43		
	19					44		
	20					45		
	21					46		
	22					47		
	23					48		
	24					49		
	25					50		
备 注								
结 论	合 格	测 试	ZL-027	审 核	ZL-029			

