

# 承认书

客户名称:

CUSTOMER NAME: \_\_\_\_\_

经办者:

职称:

DIRECTOR: \_\_\_\_\_ TITLE: \_\_\_\_\_

客户料号:

CUSTOMER PART NO.: \_\_\_\_\_

品名:

版本:

PART NUMBER:                     **KT-1206R**                     REVISION:                     **2.0**                    

发件日期:

回文日期:

ISSUE DATE:                     **2014-11-4**                     RETURN DATE:           /          /          

一、谨致执事者：兹提供敝公司产品之有关详细规格及图面数据，  
敬请给予办理测试认定手续。

同时敬请送返一份附有贵公司签认之测试认定后之样品认定书。

We are please in sending you herewith our specification and drawings for your approval.

Please return to us one copy "For Approval" with your approved signatures.

二、附件:

ACCESSORY: 样品 出货检验记录表 封装尺寸图 电气特性曲线

内部线路图 焊性建议 PAD 建议 包装方式

三、客户意见栏 CUSTOMER'S PROPOSAL

AGREE 同意 (请于认可栏中签名)

DISAGREE 不同意

REASON 原因: \_\_\_\_\_

客户认可签章:

CUSTOMER SIGNATURE: \_\_\_\_\_



## Features

- \_3.2mmX1.6mm SMT LED, 0.90mm THICKNESS.
- \_LOW POWER CONSUMPTION.
- \_WIDE VIEWING ANGLE.
- \_IDEAL FOR BACKLIGHT AND INDICATOR.
- \_VARIOUS COLORS AND LENS TYPES AVAILABLE.
- \_PACKAGE: 3000PCS / REEL.
- \_RoHS COMPLIANT.

## Description

The Hyper Red source color devices are made with DH InGaAlP on GaAs substrate Light Emitting Diode

## Package Dimensions

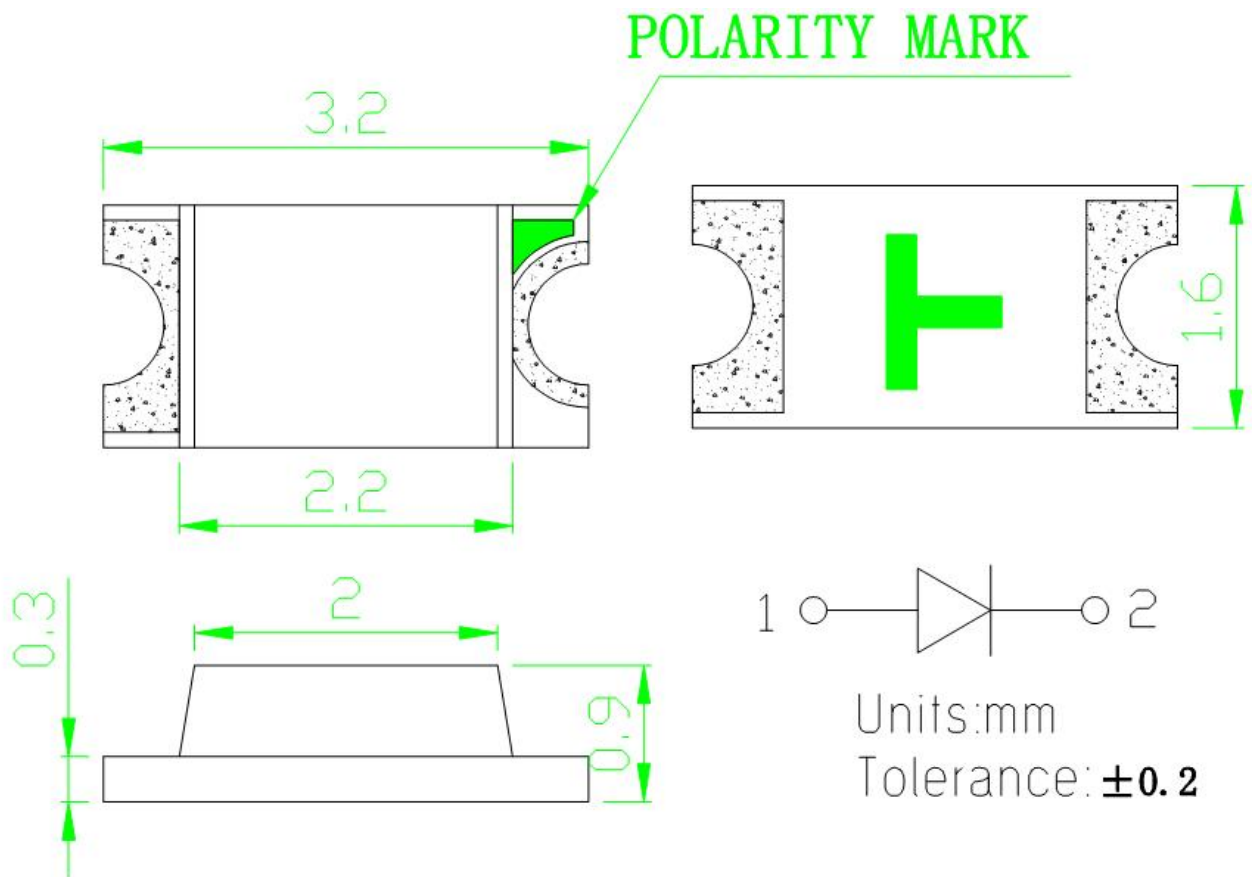

## Notes:

1. All dimensions are in millimeters (inches).
2. Tolerance is  $\pm 0.1$  (0.004") unless otherwise noted.
3. Specifications are subject to change without notice.



## Selection Guide

Part No.	Dice	Lens Type	Iv (mcd) @ 20mA		Viewing Angle
			Min.	Typ.	2 θ 1/2
<b>KT-1206R</b>	<b>RED</b>	<b>WATER CLEAR</b>	<b>70</b>	<b>150</b>	<b>120</b>

### Note:

1. θ1/2 is the angle from optical centerline where the luminous intensity is 1/2 the optical centerline value.

## Electrical / Optical Characteristics at TA=25°C

Symbol	Parameter	Device	Typ.	Max.	Units	Test Conditions
λ <sub>peak</sub>	Peak Wavelength	RED	617	625	nm	IF=20mA
λ <sub>D</sub>	Dominant Wavelength	RED			nm	IF=20mA
Δλ <sub>1/2</sub>	Spectral Line Half-width	RED	25		nm	IF=20mA
C	Capacitance	RED	105		pF	VF=0V;f=1MHz
VF	Forward Voltage	RED	1.9	2.2	V	IF=20mA
IR	Reverse Current	RED		2	uA	VR = 7V

### Remarks:

If special sorting is required (e.g. binning based on forward voltage, luminous intensity, or wavelength), the typical accuracy of the sorting process is as follows:

1. Wavelength: +/-1nm
2. Luminous Intensity: +/-15%
3. Forward Voltage: +/-0.1V

Note: Accuracy may depend on the sorting parameters

## Absolute Maximum Ratings at TA=25°C

Parameter	RED	Units
Power dissipation	75	mW
DC Forward Current	30	mA
Peak Forward Current [1]	80	mA
Reverse Voltage	5	V
Operating/Storage Temperature	-40°C To +85°C	

### Note:

1. 1/10 Duty Cycle, 0.1ms Pulse Width.

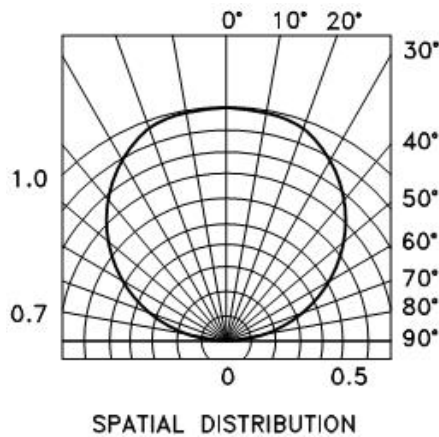
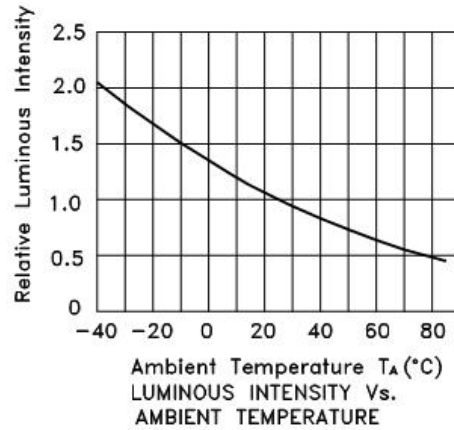
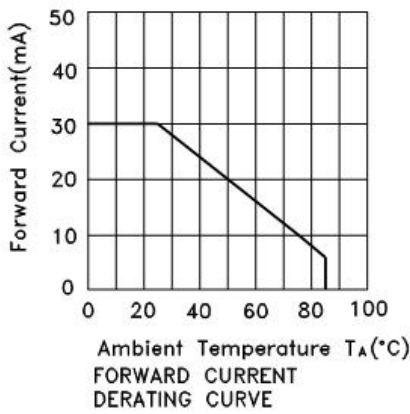
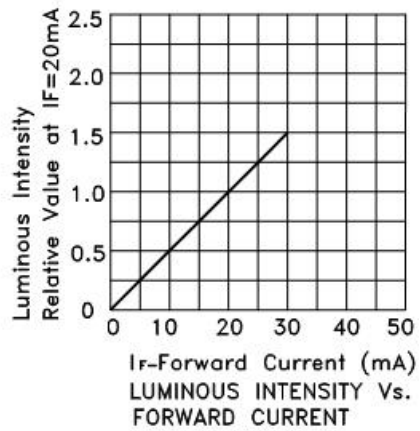
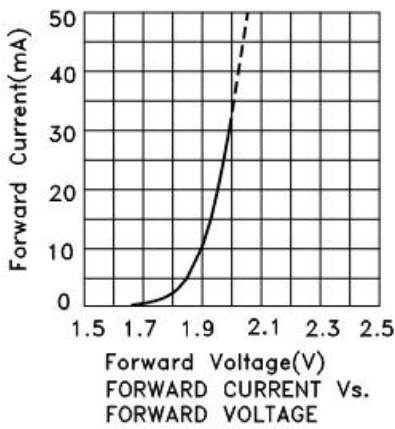
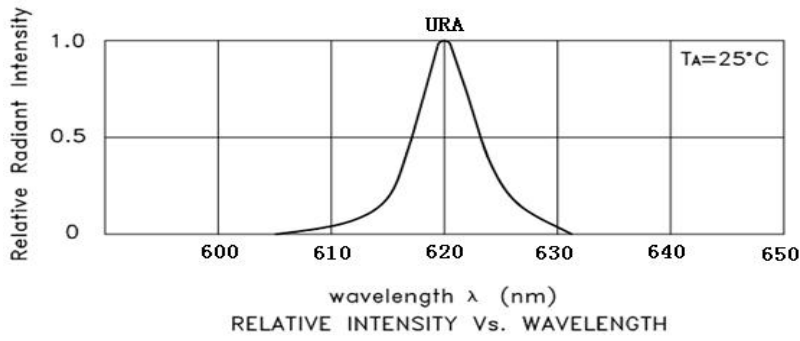



可靠性 RELIABILITY

测试项目及结果 Test Items and Results

序号	试验项目	参考标准	试验条件	持续时间	取样数	接收水准(不合格
						数量/抽样总数)
1	温度循环	JEITA ED-4701	-40℃~25℃~100℃~ 25℃ 30 分钟 5 分钟 30 分 钟 5 分钟	循环 100 回 合	50	0/50
2	冷热冲击	MIL-STD-202G	-40℃~100℃ 15 分钟 15 分钟	循环 500 回 合	50	0/50
3	高温储存	JEITA ED-4701 200 201	T <sub>a</sub> =100℃	1000 小 时	50	0/50
4	低温储存	JEITA ED-4701 200 201	T <sub>a</sub> =-40℃	1000 小 时	50	0/50
5	常温寿命 试验		T <sub>a</sub> =25±5℃  I <sub>f</sub> =20mA	1000 小 时	50	0/50
6	高温高湿 寿命试验		T <sub>a</sub> =60℃ RH=85%  I <sub>f</sub> =20mA	1000 小 时	50	0/50
7	可焊性 (回流焊)	JEITA ED-4701 300 303	T <sub>sol</sub> =235℃±5℃,5 秒 使用助焊剂	焊接一 次, 5 秒	10	0/10
8	耐焊性 (回流焊)	JEITA ED-4701 300 301	T <sub>sol</sub> =260℃,10 秒 预处理: 35℃ 95%RH 96 小时	焊接二 次, 每次 10 秒	10	0/10
备注	以上试验项目如与客户试验要求存在差异的或者特殊客户特殊要求的可根据实际情况按照客					
	户的要 求进行试作,客户未要求的按我司试验标准试作.不同产品使用不同电流进行测试					

## 5. 注意事项 Cautions

### (1) 焊接条件 Soldering Conditions

本产品最多只可回焊两次,且在首次回焊后须冷却至室温之后方可进行第二次回焊.

Number of reflow process shall be less than 2 times and cooling process to normal temperature is required between first and Second soldering process.

推荐焊接条件(Recommended soldering conditions)

回流焊接 Reflow Soldering		手工焊接	
预热温度 Pre-heat	有铅 Lead Solder	无铅 Lead-free Solder	温度 Temperature
预热时间 Pre-heat time	140 ~ 160° C 120 sec. Max.	180 ~ 200° C 120 sec. Max.	焊接时间 Soldering time
峰值温度 Peak temperature	230° C Max. 10 sec. Max.	240° C Max. 10 sec. Max.	350° C Max. 3 sec. Max. (one time only)
焊接时间 Soldering time	参考下图	参考下图	
条件 Condition			

有铅回焊 (Lead Solder)

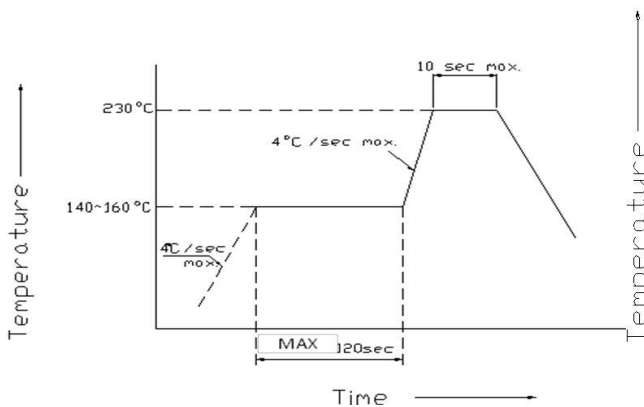

无铅回焊 (Lead-Free Solder)

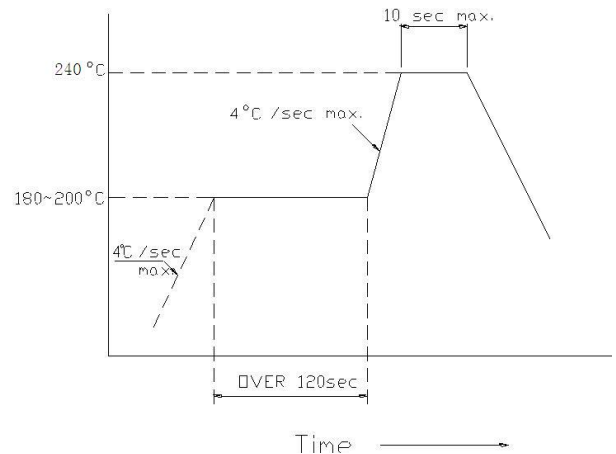

**Recommended Solderii**  
(Units : mm)

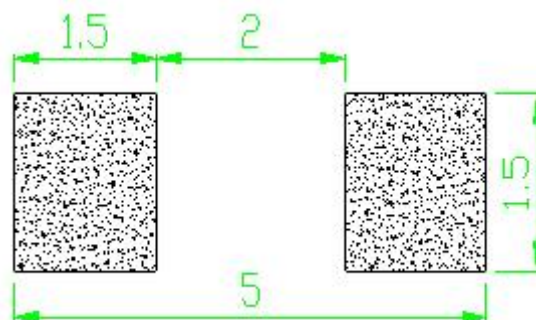



## (2) 静电 Static Electricity

触摸 LED 时,推荐使用防静电手腕带或防静电手套.

It is recommended that a wrist band or an anti-electrostatic glove be used when handling the LEDs.

所有装置、设备、机器均应接地.

All devices, equipment and machinery must be properly grounded.

静电损坏的 LED 会显示出异常特征:正向电压变低或在低电流时死灯.标准:  $I_F=0.5\text{mA}$  时,  $V_F > 2.0\text{V}$  Damaged LEDs will show some unusual characteristics such as the forward voltage becomes lower, or the LEDs do not light at the low current. Criteria : ( $V_F > 2.0\text{V}$  at  $I_F=0.5\text{mA}$ )

## (3) 防潮包装 Moisture Proof Package

使用防潮包装

It is recommended that moisture proof package be used .

## (4) 使用注意事项

Cautions:

4.1. 在开包装之前, 请先检查包装袋有无漏气, 如果有漏气现象, 请退回我司重新烘烤除湿包装后再使用。

Please check if there is air leak before opening the package, if so, please return the goods back to take drying process for later using.

4.2 抽真空包装材料未超过 15 天可正常使用, 包装袋开启后, 产品必须:

Products can be used within 15days after packaging, after that, they must be:

4.2.1 在 24hrs 内未焊接完毕。

Soldered within 24 hrs

4.2.2 要在规定环境条件中使用: 温度: $30^{\circ}\text{C}$ 以内 湿度: $60\%RH$  以下

Used in the condition:  $30^{\circ}\text{C}$  within and  $60\%RH$  below

4.2.3 存储低于  $30\%RH$ 。

Stored in  $30\%RH$  for moisture below.

4.3. 抽真空包装材料超过 15 天(含)以上未使用, 再使用时需重新拆铝箔袋取出烘烤  $85^{\circ}\text{C}/6\text{H}$  除湿后才可使用。

Products cannot be used for and over 15days after being packaged unless opening the package and take drying our process in  $85^{\circ}\text{C}/6\text{H}$ .

4.4. 抽真空包装材料超过 60 天(含)以上未使用, 请退回我司重新烘烤除湿包装后再使用。

Products not be used for or over 60days after being packaged please return back to take drying out and packaging process for forward using.

4.5. 材料拆装后使用时间超过 24H 未用完, 需烘烤  $85^{\circ}\text{C}/6\text{H}$  除湿后才可使用。



Products not be used after opening the package need to be dried out for 85°C/6H

## 包装 PACKAGING

LEDS 在装带之后纸箱包装. The LEDs are packed in cardboard boxes after taping.

### 包装方式:

TAPE

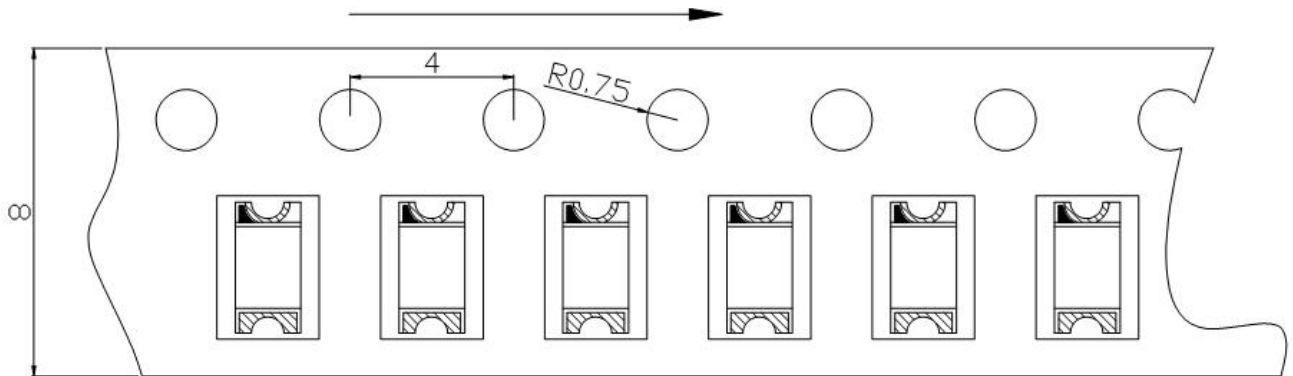

Package: 3000 pcs/reel

### Reel Dimensions

卷轴尺寸

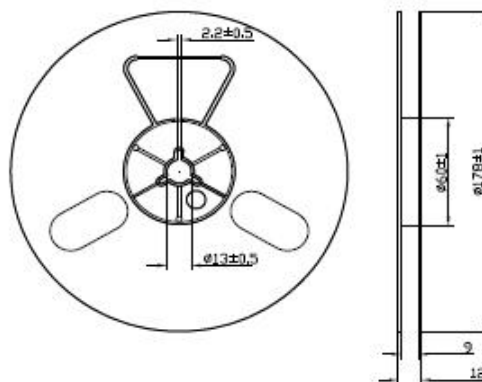

### Moisture Resistant Packaging 防潮带包装

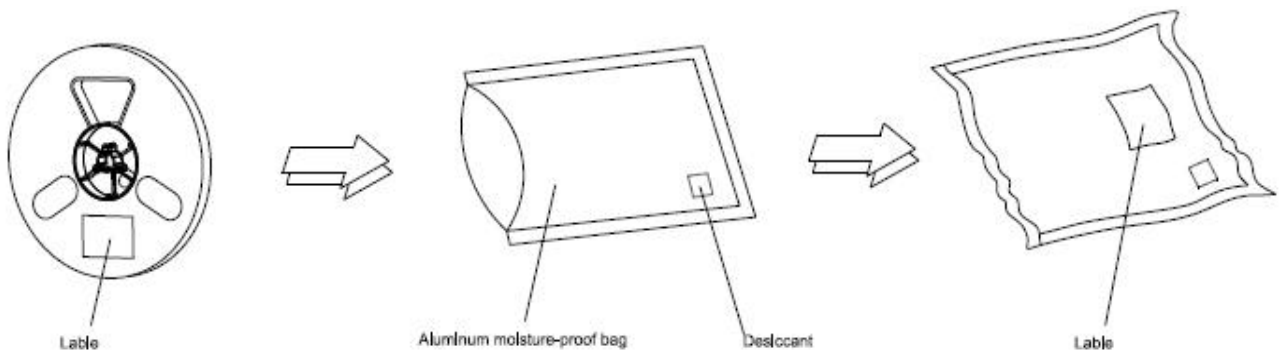





# 湖北匡通电子股份有限公司<sup>8</sup>

Note: The tolerances unless mentioned is  $\pm 0.1\text{mm}$ , Unit: mm 注: 标注公差为  $\pm 0.1\text{MM}$ , 单位: MM