

RECOMMENDED PCB LAYOUT

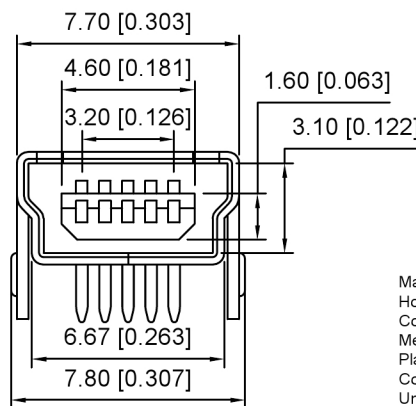
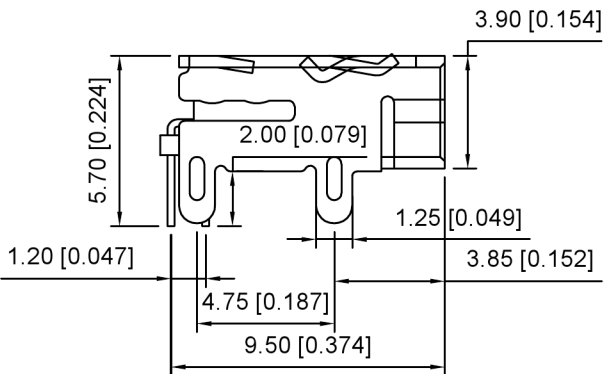
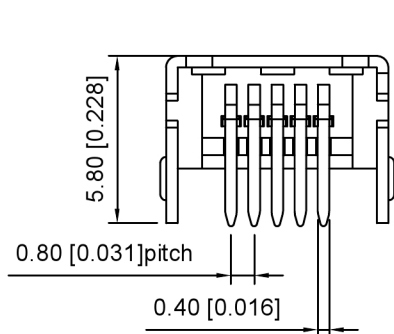

Material
 Housing Material: LCP, UL94V-0, black
 Contact Terminal: Copper Alloy C2680, T=0.25mm
 Metallic Shell: Copper Alloy C2680, T=0.4mm
 Plating
 Contact Terminal
 Underplating: Nickel all over
 Contact Plating: 1μ" gold
 Solder Tail: Bright Tin
 Metallic Shell
 Underplating: Nickel 50μ" all over
 Metallic Shell: Matte Tin 50μ" all over
 Electrical
 Voltage Rating: 30VDC
 Current Rating: 1A
 Contact Resistance: 50mΩ Max
 Insulation resistance: 100MΩ Min (Apply 100 VDC)
 Dielectric withstanding voltage: No discharge or flash (100V AC is applied for 1 minute)
 Mechanical
 Durability: 5,000 cycles
 Mating Force: 35N (3.57Kgf) Max
 Unmating Force: Initial - 7N (0.71KgF) Min., 5001st cycle - 3N (0.31KgF) Min.
 Environmental and Processing
 Operating Temperature: -50°C to +85°C

U214-05XN-4BR84

1: Au 1U"
 6: Au 30U"

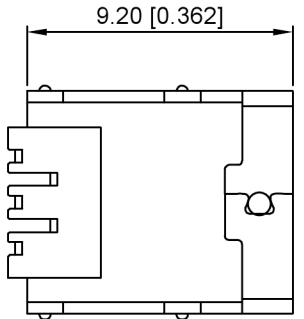

广东星坤科技股份有限公司

| | |
|------|-------------|
| ΔX | 日期 |
| ΔX | 日期 |
| ΔX | 日期 |
| MARK | DESCRIPTION |

文件工程章

| REVISIONS | DATE | REVISED | APPROVED | DESCRIPTION |
|------------------------|------|---------|----------|-------------|
| UNSPECIFIED TOLERANCES | | | | |

www.helloxkb.com www.helloxkb.cn www.xk-dg.cn



| | | |
|---------------------------------------|-------------|-------------------------|
| DSND | SCALE: N/A | MODEL TYPE: MINI USB |
| DWN | VIEW: | PART NO.: |
| CHKD | UNIT: mm/in | DWG NO.: |
| APPD | SIZE: A4 | U214-05XN-4BR84 |
| XKB INDUSTRIAL PRECISION CO., LIMITED | | WEIGHT SHEET REVISION |
| | | 1/1 A0 |