

**Specification**

**MATERIAL:**  
 Insulator: LCP UL94V-0, BLACK  
 Contact: C5210  
 SHELL: SUS304

**PLATING:**  
 Contact: G/F OVER Ni  
 Shell: G/F PLATED ON SOLDER AREAN;  
 PLATED OVERALL

**Electrical:**  
 Current Rating :0.5mA AC/DC max.  
 Voltage Rating :125V AC/DC  
 Ambient Temperature Range :-20C~+60°C  
 Storage Temperature Range :-40C~+70°C  
 Ambient Humidity Range :95% R.H. Max.  
 Contact Resistance:100mΩ max.  
 Insulation Resistance 1000MΩ min./500VDC  
 Mating Cycles:10,000 Insertions  
 Reflow peak temp: 260°C +50, 3~5 S  
 Mating Cycles:3,000 Insertions Min

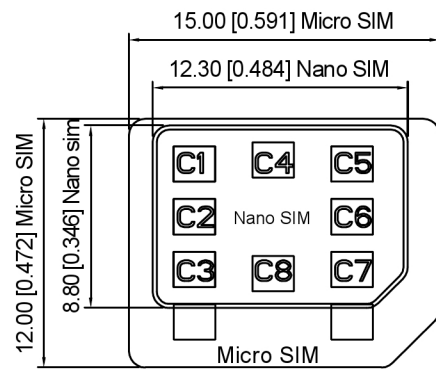
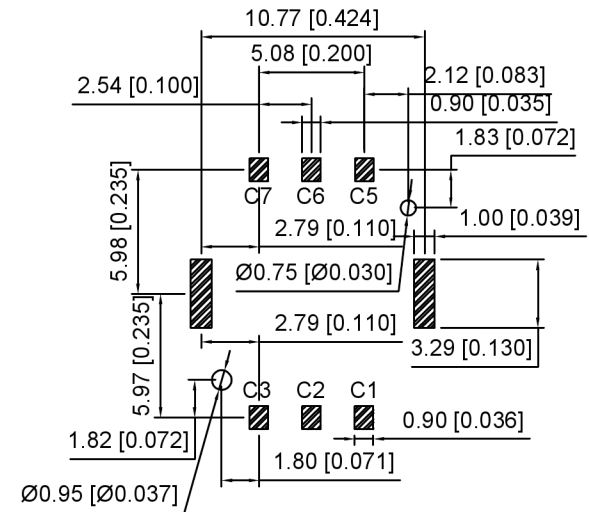
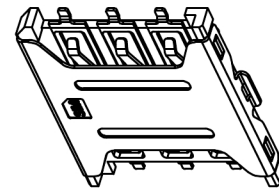
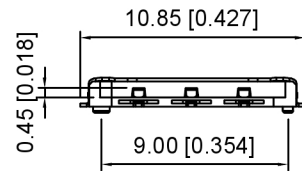

SIM pin assignment	
PIN#	Name
C1	VCC供电电压
C2	RST重置
C3	CLK时钟
C5	GND接地
C6	VPP程序电压
C7	I/O输入输出

广东星坤科技股份有限公司

日期

文件工程章

DATE	REVISED	APPROVED	DESCRIPTION

REVISIONS

UNSPECIFIED TOLERANCES

DSND	SCALE: N/A	MODEL TYPE: SIM CARD CONN
DWN	VIEW:	PART NO.:
CHKD	UNIT: mm/in	DWG NO.:
APPD	SIZE: A4	XKSIM-304
XKB INDUSTRIAL PRECISION CO., LIMITED		WEIGHT
		SHEET
		REVISIOI
		1/1
		A0

